

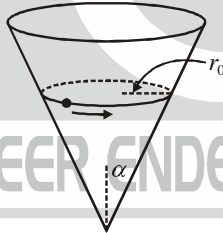

GS-2015-X (PHYSICS)_TIFR

SECTION – A

- Which of the following vectors is parallel to the surface $x^2y + 2xz = 4$ at the point $(2, -2, 3)$?
 (a) $+6\hat{i} - 2\hat{j} - 5\hat{k}$ (b) $+6\hat{i} + 2\hat{j} + 5\hat{k}$ (c) $-6\hat{i} - 2\hat{j} + 5\hat{k}$ (d) $+6\hat{i} - 2\hat{j} + 5\hat{k}$
- A random number generator outputs $+1$ or -1 with equal probability every time it is run. After it is run 6 times, what is the probability that the sum of the answers generated is zero? Assume that the individual runs are independent of each other.
 (a) $\frac{1}{2}$ (b) $\frac{5}{6}$ (c) $\frac{5}{16}$ (d) $\frac{15}{32}$
- It is required to construct the quantum theory of a particle of mass m moving in one dimension x under the influence of a constant force F . The characteristic length-scale in this problem is
 (a) $\frac{\hbar}{mF}$ (b) $\left(\frac{\hbar^2}{mF}\right)^{1/3}$ (c) $\left(\frac{\hbar}{m^2F}\right)^{1/3}$ (d) $\frac{mF}{\hbar^2}$
- A particle slides on the inside surface of a frictionless cone. The cone is fixed with its tip on the ground and its axis vertical, as shown in the figure on the right. The semi-vertex angle of the cone is α . If the particle moves in a circle of radius r_0 , without slipping downwards, the angular frequency ω of this motion will be

 (a) $\sqrt{\frac{g}{r_0 \cos \alpha}}$ (b) $\sqrt{\frac{g}{r_0 \sin \alpha}}$ (c) $\sqrt{\frac{g}{r_0 \cot \alpha}}$ (d) $\sqrt{\frac{g}{r_0 \tan \alpha}}$
- A car starts from rest and accelerates under a force F increasing linearly in time as $F = at$ where a is a constant. At time $t_1 > 0$, the force F is suddenly switched off. At a later time $t_2 > t_1$, brakes are applied resulting in a force F' whose magnitude increases linearly with time, $F' = -a(t - t_2)$ where a is the same constant as before. Which of the following graphs would best represent the change in the position of the car $x(t)$ with time?



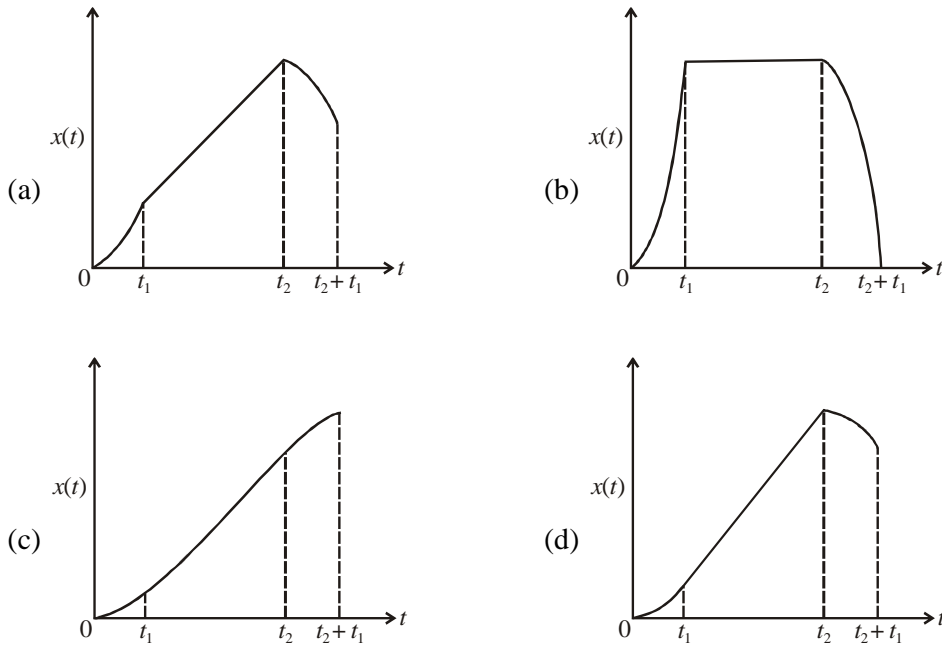

6. In the Earth's atmosphere, a localised low-pressure region (shaded in diagrams) develops somewhere in the southern hemisphere. Which one of the following diagrams represents the correct air flow pattern as observed from a satellite ?

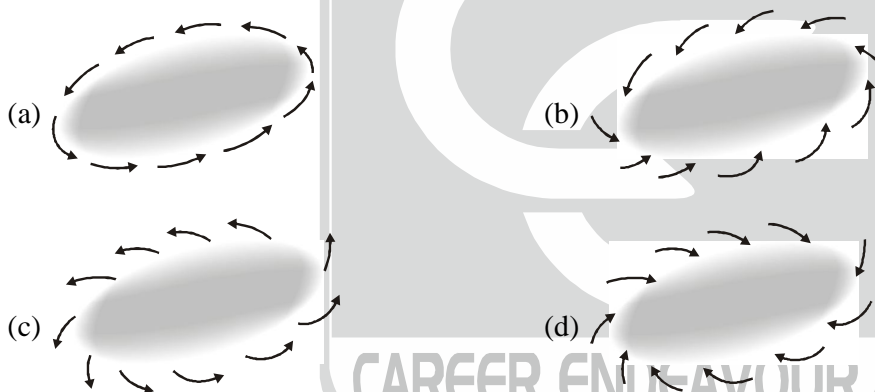

7. The focal length in air of a thin lens made of glass of refractive index 1.5 is ℓ . When immersed in water (refractive index = $4/3$), its focal length becomes
- (a) 4ℓ (b) $\frac{\ell}{4}$ (c) $\frac{3\ell}{4}$ (d) $\frac{4\ell}{3}$
8. A light beam of intensity I_0 passes at normal incidence through a flat plate of plastic kept in air. If reflection at the interface reduces the intensity by 20% and absorption on passing through the plate reduces the intensity by 2%, the intensity of the emergent beam will be about
- (a) $0.60 I_0$ (b) $0.63 I_0$ (c) $0.65 I_0$ (d) $0.78 I_0$
9. A light beam is propagating through a medium with index of refraction 1.5. If the medium is moving at constant velocity $0.7c$ in the same direction as the beam, what is the velocity of light in the medium as measured by an observer in the laboratory ? (c = velocity of light in vacuum)
- (a) $0.93c$ (b) $0.98c$ (c) $0.96c$ (d) $0.9c$

10. Two blackbodies radiate energy at temperature T_1 and T_2 ($T_1 > T_2$). The energy emitted per unit time per unit solid angle per unit surface area of a blackbody in the frequency range ν to $\nu + d\nu$ is given by $B(\nu)d\nu$. Which one of the following graphs has the correct form ?

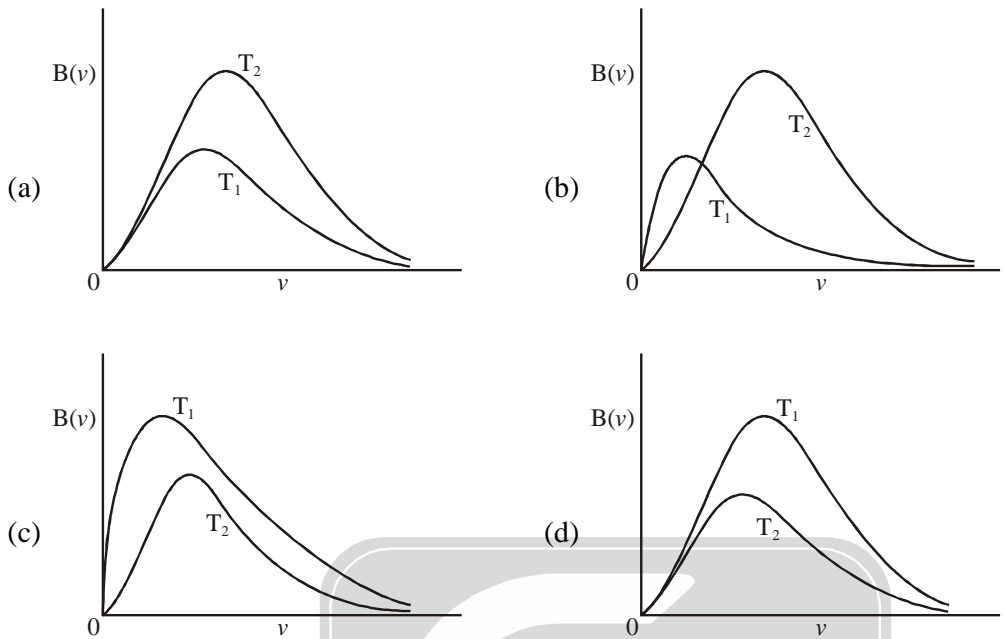

11. In a cold country, in winter, a lake was freezing slowly. It was observed that it took 2 hours to form a layer of ice 2 cm thick on the water surface. Assuming a constant thermal conductivity throughout the layer, the thickness of ice would get doubled after
 (a) 2 more hours (b) 4 more hours (c) 6 more hours (d) 8 more hours

12. Which of the following graphs qualitatively describes the pressure P of a gas of non-interacting fermions in thermal equilibrium at a constant volume as a function of temperature ?

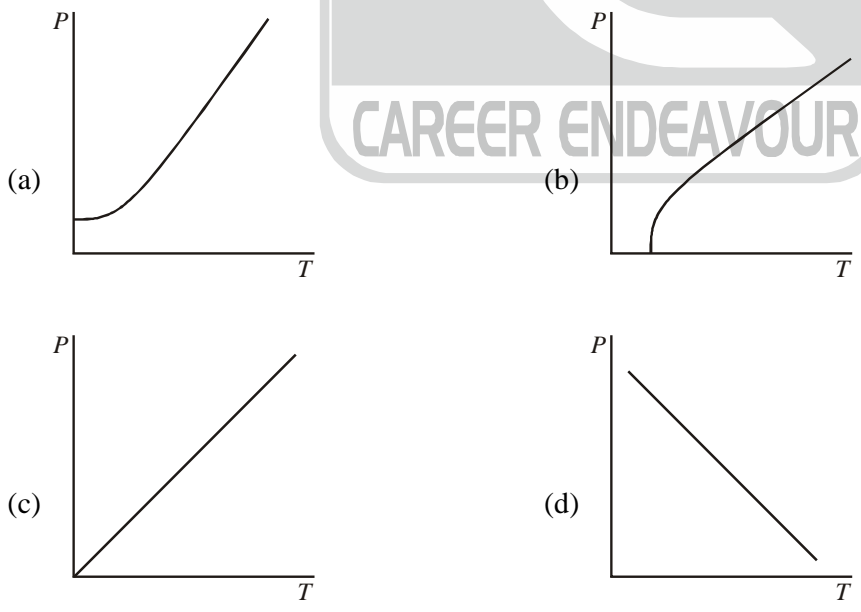

13. The electrostatic potential $\varphi(r)$ of a distribution of point charges has the form $\varphi(r) \propto r^{-3}$ at a distance r from the origin $(0,0,0)$, where $r \gg a$. Which of the following distributions can give rise to this potential ?

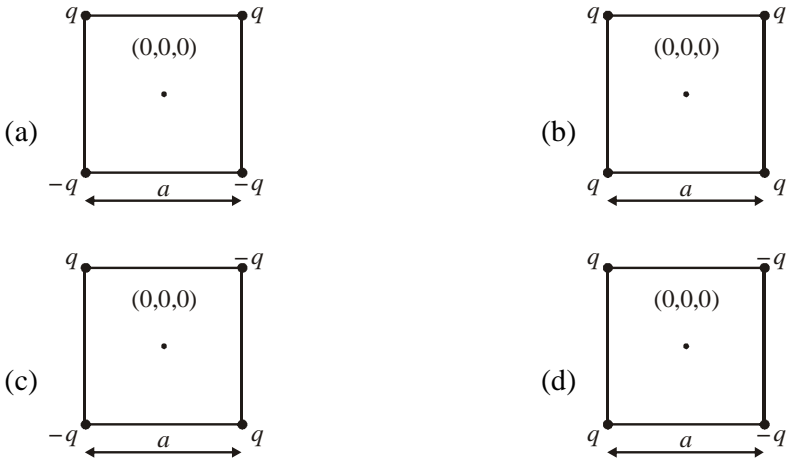

14. Two semi-infinite solenoids placed next to each other are separated by a small gap of width W as shown in the figure.

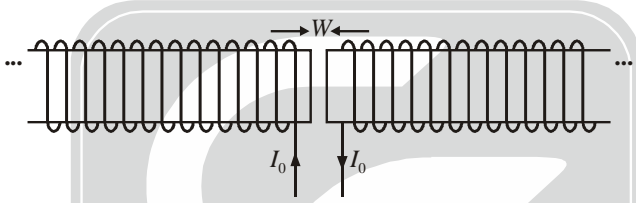

The current I_0 in the solenoids flows in the direction as shown. If the solenoids have a circular cross-section of radius R and are filled with a magnetic material of permeability $\mu(\mu > \mu_0)$, then the magnetic energy densities u_i inside the solenoid and u_g in the gap are best related by

- (a) $u_g > u_i$
- (b) $u_g < u_i$
- (c) $u_g = cu_i$
- (d) $u_g > cu_i$

15. A light source has a small filament at the centre of a spherical glass bulb of radius 5 cm and negligible thickness. If this source emits 100 Watts of power in the form of spherical electromagnetic waves, the r.m.s. electric field E at the surface of the bulb (in units of Volt/m) will be approximately
 (a) 1547 (b) 1094 (c) 109.4 (d) 15.47

16. A particle is moving in one dimension under a potential $V(x)$ such that, for large positive values of x , $V(x) \approx kx^\beta$, where $k > 0$ and $\beta \geq 1$. If the wavefunction in this region has the form $\psi(x) \sim \exp(-x^\lambda)$, which of the following is true ?

- (a) $\lambda = \frac{\beta}{2} + 1$
- (b) $\lambda = \beta$
- (c) $\lambda = 2\beta - 2$
- (d) $\lambda = \frac{\beta^2}{2}$

17. The ground state energy of a particle of mass m in a three dimensional cubical box of side ℓ is not zero but $\frac{3h^2}{8m\ell^2}$. This is because

- (a) The ground state has no nodes in the interior of the box.
- (b) This is the most convenient choice of the zero level of potential energy.
- (c) Position and momentum cannot be exactly determined simultaneously.
- (d) The potential at the boundaries is not really infinite, but just very large.



18. A one-dimensional box contains a particle whose ground state energy is ϵ . It is observed that a small disturbance causes the particle to emit a photon of energy $h\nu = 8\epsilon$, after which it is stable. Just before emission, a possible state of the particle in terms of the energy eigenstates $\{\psi_1, \psi_2, \dots\}$ would be
- (a) $\frac{\psi_1 - \psi_2}{\sqrt{2}}$ (b) $\frac{\psi_2 + 2\psi_3}{\sqrt{5}}$ (c) $\frac{-4\psi_4 + 5\psi_5}{\sqrt{41}}$ (d) $\frac{\sqrt{2}\psi_1 - 3\psi_2 + 5\psi_5}{6}$
19. A sample of ordinary hydrogen (${}^1_1\text{H}$) gas in a discharge tube was seen to emit the usual Balmer spectrum. On careful examination, however, it was found that the H_α line in the spectrum was split into two fine lines, one an intense line at 656.28 nm, and the other a faint line at 656.04 nm. From this, one can conclude that the gas sample had a small impurity of
- (a) ${}^2_1\text{H}$ (b) ${}^3_1\text{H}$ (c) ${}^4_2\text{He}$ (d) H_2O
20. An electron makes a transition from the valence band to the conduction band in an indirect band gap semiconductor. Which of the following is NOT true ?
- (a) The energy of the electron increases (b) A phonon is involved in the process
(c) A photon is absorbed in the process (d) There is no momentum change in the electron
21. Which of the following radioactive decay chains is it possible to observe ?
- (a) ${}^{206}_{82}\text{Pb} \rightarrow {}^{202}_{80}\text{Hg} \rightarrow {}^{202}_{79}\text{Au}$ (b) ${}^{210}_{83}\text{Bi} \rightarrow {}^{210}_{84}\text{Po} \rightarrow {}^{206}_{82}\text{Pb}$
(c) ${}^{214}_{88}\text{Ra} \rightarrow {}^{210}_{86}\text{Rn} \rightarrow {}^{207}_{82}\text{Pb}$ (d) ${}^{206}_{82}\text{Pb} \rightarrow {}^{202}_{80}\text{Hg} \rightarrow {}^{202}_{79}\text{Au}$
22. Which of the following is the best technique for measuring the effective mass of an electron in a semiconductor ?
- (a) Resistivity measurements (b) X-rays diffraction experiment
(c) Cyclotron resonance (d) Millikan's oil drop experiment
23. Two LCR circuits (A) and (B) are shown below where $C_c \ll C$. At time $t = 0$, a charge Q is put on the capacitor C .

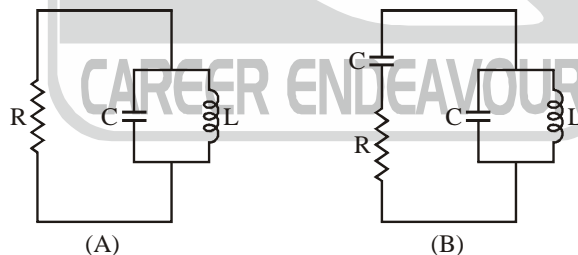

Which of the following statements is correct ?

- (a) The charge Q will decay faster in (A)
(b) The charge Q will decay faster in (B)
(c) The charge Q will decay at the same rate in (A) and (B)
(d) The relative decay rates cannot be predicted without knowing the exact values of L , C , R and C_c

24. In the circuit shown below, the op-amp is powered by a bipolar supply of ± 10 V.

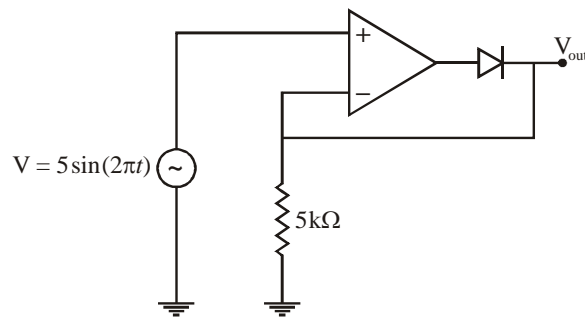

Which one of the following graphs represents V_{out} correctly ?

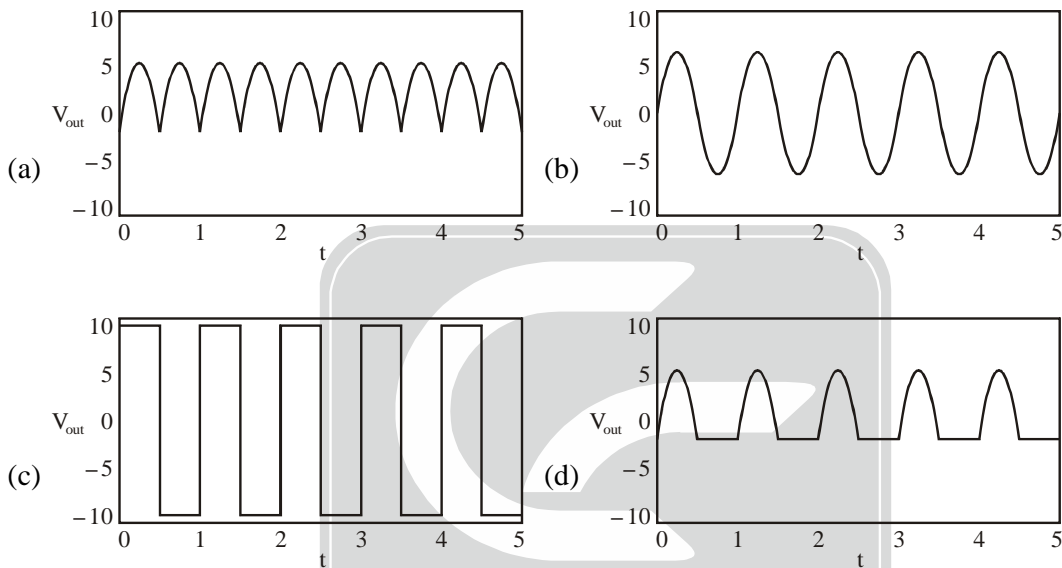

25. All resistors in the circuit on the right have a tolerance of $\pm 5\%$.

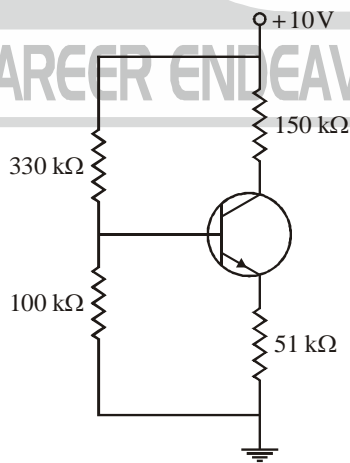

Assuming a diode drop of 0.7 V, which of the following is the lowest possible value of the collector voltage ?

- (a) 3.1 V
- (b) 4.1 V
- (c) 4.7 V
- (d) 5.2 V



SECTION – B

26. Consider the differential equation

$$\frac{d^2y}{dx^2} = -4 \left(y + \frac{dy}{dx} \right)$$

with the boundary condition that $y(x) = 0$ at $x = 1/5$. When plotted as a function of x , for $x \geq 0$, we can say with certainty that the value of y

- (a) oscillates from positive to negative with amplitude decreasing to zero
 (b) has an extremum in the range $0 < x < 1$
 (c) first increases, then decreases to zero
 (d) first decreases, then increases to zero
27. In a transmission diffraction grating, there are 10^4 lines/mm. Which of the following ranges of wavelength (in nm) will produce at least one principal maximum ?
 (a) 1 – 200 (b) 201 – 500 (c) 501 – 1000 (d) 1001 – 5000
28. Two cylinders A and B of the same length L and outer radius R were placed at the same height h on an inclined plane at an angle ϕ with the horizontal (see figure). Starting from rest, each cylinder was allowed to roll down the plane without slipping. It was found that A reached the end of the inclined plane earlier than B. Which of the following possibilities could be true ?

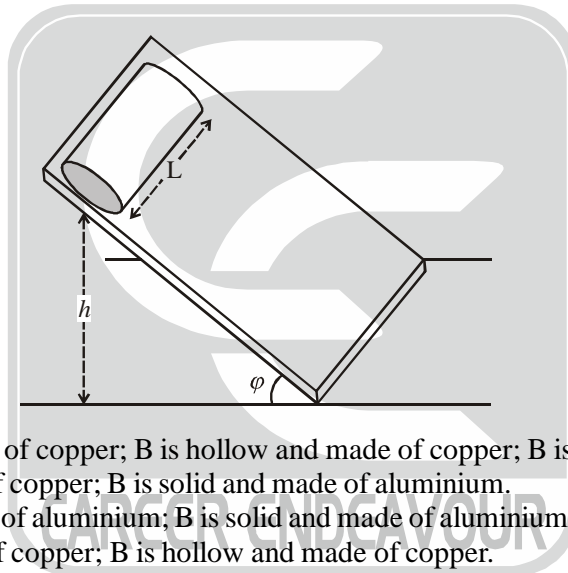

- (a) A is hollow and made of copper; B is hollow and made of copper; B is heavier than A.
 (b) A is solid and made of copper; B is solid and made of aluminium.
 (c) A is hollow and made of aluminium; B is solid and made of aluminium.
 (d) A is solid and made of copper; B is hollow and made of copper.
29. A thin uniform rod of length $2l$ and mass M is pivoted at one end P on a horizontal plane (see figure). A ball of mass $m \ll M$ and speed v_0 strikes the free end of the rod perpendicularly and bounces back with velocity v_f along the original line of motion as shown in the figure. If the collision is perfectly elastic the magnitude of v_f is

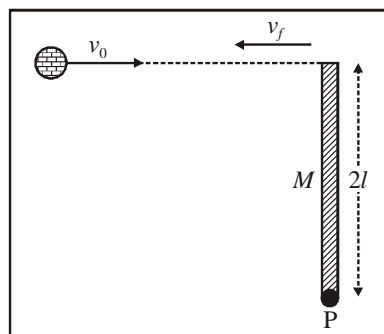

(a) $\frac{M-4m}{M+4m}v_0$ (b) $\frac{M+4m}{M-4m}v_0$ (c) $\frac{M-3m}{M+3m}v_0$ (d) $\frac{M+3m}{M-3m}v_0$

30. A collimated beam of pions originate from an accelerator and propagates in vacuum along a long straight beam pipe. The intensity of this beam was measured in the laboratory after a distance of 75 m and found to have dropped to one-fourth of its intensity at the point of origin. If the proper half-life of a pion is 1.77×10^{-8} s, the speed of the pions in the beam, as measured in the laboratory, must be
 (a) $0.99c$ (b) $0.98c$ (c) $0.97c$ (d) $0.96c$
31. The equation of state of a gas is given by

$$V = \frac{RT}{P} - \frac{b}{T}$$

where R is the gas constant and b is another constant parameter. The specific heat at constant pressure C_p and the specific heat at constant volume C_v for this gas is related by $C_p - C_v =$

(a) R (b) $R\left(1 + \frac{RT^2}{bP}\right)^2$ (c) $R\left(1 + \frac{bP}{RT^2}\right)^2$ (d) $R\left(1 - \frac{bP}{RT^2}\right)^2$

32. An ideal diatomic gas is initially at a temperature $T = 0^\circ\text{C}$. Then it expands reversibly and adiabatically to 5 times its volume. Its final temperature will be approximately
 (a) -180°C (b) -150°C (c) -130°C (d) 0°C
33. Consider an infinitely long cylinder of radius R , placed along the z -axis, which carries a static charge density $\rho(r) = kr$, where r is the perpendicular distance from the axis of the cylinder and k is a constant. The electrostatic potential $\phi(r)$ inside the cylinder is proportional to
 (a) $-\frac{2}{3}\left(\frac{r^3}{R^3} + 1\right)$ (b) $-2 \ln\left(\frac{r}{R}\right)$ (c) $-\frac{2}{3}\left(\frac{r^3}{R^3} - 1\right)$ (d) $-2 \ln\left(\frac{R}{r}\right)$
34. A solid spherical conductor encloses 3 cavities, a cross-section of which are as shown in the figure. A net charge $+q$ resides on the outer surface of the conductor. Cavities A and C contain point charges $+q$ and $-q$, respectively.

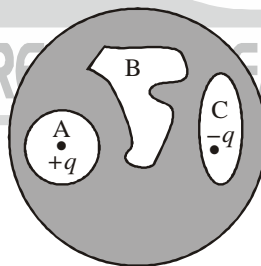

The net charges on the surfaces of these cavities are

(a) $A = -q, B = q, C = 0$ (b) $A = -q, B = 0, C = -q$
 (c) $A = +q, B = 0, C = -q$ (d) $A = -q, B = 0, C = +q$

35. 1000 neutral spinless particles are confined in a one-dimensional box of length 100 nm. At a given instant of time, if 100 of these particle have energy $4\epsilon_0$ and the remaining 900 have energy $225\epsilon_0$, then the number of particles in the left half of the box will be approximately
 (a) 625 (b) 500 (c) 441 (d) 100



36. A one-dimensional quantum harmonic oscillator is in its ground state

$$\psi_0(x) = \left(\frac{m\omega}{\pi\hbar}\right)^{1/4} e^{-m\omega x^2/2\hbar}$$

Two experiments, [A] and [B], are performed on the system. In [A], the frequency ω of the oscillator is suddenly doubled, while in [B] the frequency ω is suddenly halved. If p_A and p_B denote the probability in each case that the system is found in its new ground state immediately after the frequency change, which of the following is true ?

- (a) $p_A = \sqrt{2}p_B$ (b) $p_A = 2p_B$ (c) $2p_A = p_B$ (d) $p_A = p_B$
37. In the basic band structure theory of crystalline solids, which of the following leads to energy gaps in the allowed electronic energy values ?
- (a) Electron spin (b) Bragg reflection
(c) Electron-electron interaction (d) Electron-phonon interaction
38. The material inside a box is either a metal or a semiconductor. If $R (= 1 \Omega)$ is the resistance of the material, which of the following experiments CANNOT distinguish whether it is a metal or a semiconductor ?
- (a) Measurement of R using power supplies of different frequencies.
(b) Measurement of absorption spectrum in the energy range 0.1 – 2 eV.
(c) Measurement of R at different temperatures.
(d) Measurement of R in the presence of different magnetic fields.
39. To measure the voltage in the range 0 – 5 V with a precision of 5 mV, the minimum number of bits required in a digital voltmeter is
- (a) 9 (b) 10 (c) 11 (d) 12
40. A building has three overhead water tanks, each fitted with a sensor (S_1, S_2, S_3) which goes to 0 when the water level in the tank falls below a set value and remains 1 otherwise. A common pump is used to raise water from an underground storage tank to these overhead tanks. Of the following circuits, which one will turn on ($P = 1$) the pump only when at least two of the tanks have water level below the set value ?

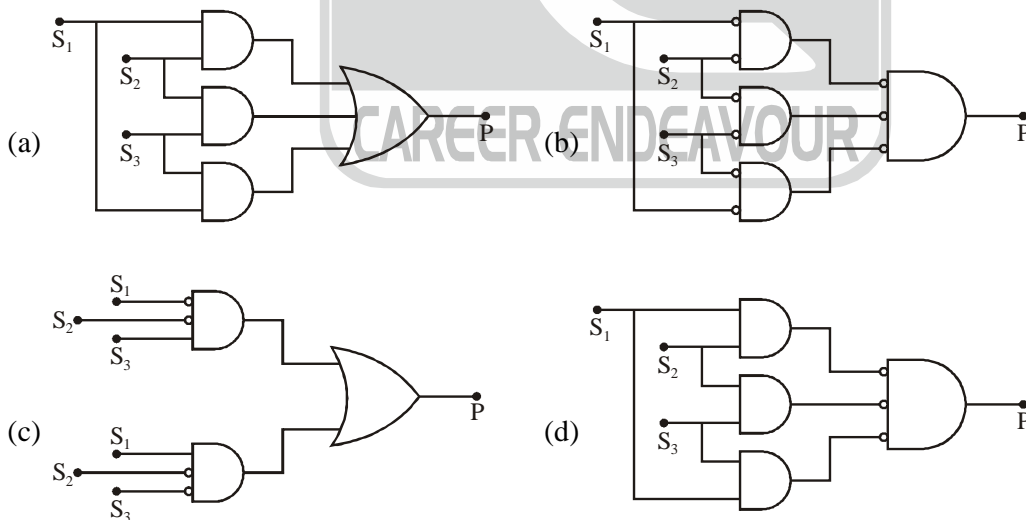

SECTION – C

41. The integral

$$\int_0^{2\pi} \frac{d\theta}{1 - 2a \cos \theta + a^2}$$

where $0 < a < 1$, evaluate to

- (a) 2π (b) $\frac{2\pi}{1+a^2}$ (c) $\frac{2\pi}{1-a^2}$ (d) $\frac{4\pi}{1-a^2}$

42. The generating function for a set of polynomials in
- x
- is given by

$$f(x, t) = (1 - 2xt + t^2)^{-1}$$

The third polynomial (order x^2) in this set is

- (a) $2x^2 + 1$ (b) $2x^2 - x$ (c) $4x^2 + 1$ (d) $4x^2 - 1$

43. A particle moves under the influence of a central potential in an orbit
- $r = k\theta^4$
- , where
- k
- is a constant and
- r
- is the distance from the origin. It follows that the angle
- θ
- varies with time
- t
- as

- (a) $\theta \propto t^{1/9}$ (b) $\theta \propto t^{1/8}$ (c) $\theta \propto t^{1/7}$ (d) $\theta \propto t^{1/6}$

44. In a system with two degrees of freedom, if
- (p, q)
- are the canonical coordinates, then which of the following transformations to
- (P, Q)
- is canonical?

(a) $P = \frac{1}{2}(p^2 + q^2), Q = \tan^{-1} \frac{2q}{p}$ (b) $P = \frac{1}{2}(p^2 + q^2), Q = \cot^{-1} \frac{p}{q}$

(c) $P = \frac{1}{2}(p^2 + q^2), Q = \sin^{-1} \frac{q}{2p}$ (d) $P = \frac{1}{2}(p^2 + q^2), Q = \cos^{-1} \frac{p}{q}$

45. In a monatomic gas, the first excited state is only 1.5 eV above the ground state, while the other excited states are much higher up. The ground state is doubly-degenerate, while the first excited state has a four-fold degeneracy. If now, the gas is heated to a temperature of 7000 K, the fraction of atoms in the excited state will be approximately

- (a) 0.14 (b) 0.07 (c) 0.42 (d) 0.3

46. Measurement of the magnitudes of the electric field (
- E
-) and the magnetic field (
- B
-) in a plane polarized electromagnetic wave in vacuum leads to the following results

$$\frac{\partial E}{\partial y} = -\frac{\partial B}{\partial t} \quad \frac{\partial B}{\partial y} = -\frac{1}{c^2} \frac{\partial E}{\partial t}$$

at all points where the measurement is made. In this case the electric vector \vec{E} , the magnetic vector \vec{B} and the wave vector \vec{k} (with magnetic k) can be written in terms of the unit vectors $(\hat{x}, \hat{y}, \hat{z})$ along the Cartesian axes as

- (a) $\vec{E} = E\hat{x}, \vec{B} = B\hat{y}, \vec{k} = k\hat{z}$ (b) $\vec{E} = E\hat{x}, \vec{B} = B\hat{z}, \vec{k} = -k\hat{y}$
 (c) $\vec{E} = E\hat{x}, \vec{B} = -B\hat{z}, \vec{k} = k\hat{y}$ (d) $\vec{E} = -E\hat{y}, \vec{B} = -B\hat{z}, \vec{k} = -k\hat{x}$

47. A two state quantum system has two observables
- A
- and
- B
- . It is known that the observable
- A
- has eigenstates
- $|\alpha_1\rangle$
- and
- $|\alpha_2\rangle$
- with eigenvalues
- a_1
- and
- a_2
- respectively, while
- B
- has eigenstates
- $|\beta_1\rangle$
- and
- $|\beta_2\rangle$
- with eigenvalues
- b_1
- and
- b_2
- respectively, and that these eigenstates are related by

$$|\beta_1\rangle = \frac{3}{5}|\alpha_1\rangle - \frac{4}{5}|\alpha_2\rangle \quad |\beta_2\rangle = \frac{4}{5}|\alpha_1\rangle + \frac{3}{5}|\alpha_2\rangle$$



Suppose a measurement is made of the observable A and a value a_1 is obtained. If the observable B is now measured, the probability of obtaining the value b_1 will be

- (a) 0.80 (b) 0.64 (c) 0.60 (d) 0.36

48. An rigid rotator has the wave function

$$\psi(\theta, \varphi) = N \left[2i Y_{1,0}(\theta, \varphi) + (2 + i) Y_{2,-1}(\theta, \varphi) + 3i Y_{1,1}(\theta, \varphi) \right]$$

where $Y_{l,m}(\theta, \varphi)$ are the spherical harmonics, and N is a normalization constant. If \vec{L} is the orbital angular momentum operator, and $L_{\pm} = L_x \pm iL_y$ the expectation value of L_+L_- is

- (a) $\frac{21\hbar^2}{9}$ (b) $\frac{23\hbar^2}{9}$ (c) $\frac{25\hbar^2}{9}$ (d) 0

49. In the ground state electronic configuration of nitrogen (${}^{14}_7\text{N}$) the L , S and J quantum numbers are

(a) $L = 1, S = \frac{1}{2}, J = \frac{1}{2}$ (b) $L = 1, S = \frac{1}{2}, J = \frac{3}{2}$

(c) $L = 0, S = \frac{1}{2}, J = \frac{1}{2}$ (d) $L = 0, S = \frac{3}{2}, J = \frac{3}{2}$

50. Solar radiation tends to push any particle inside solar system away from the Sun. Consider a spherical dust particle of specific gravity 6.0 and no angular momentum about the Sun. What should be its minimum radius so that it does not escape from the solar system? Take the solar luminosity to be 3.8×10^{26} W.

- (a) $10^{-6} \mu\text{m}$ (b) $0.01 \mu\text{m}$ (c) $0.1 \mu\text{m}$ (d) $10 \mu\text{m}$

51. Bosonic excitations of ferromagnets have a dispersion relation $\epsilon = \gamma k^2$, where ϵ is the energy and k is the wavevector of the excitation. Assuming a system of such non-interacting bosonic excitation, at low temperature T , the specific heat C_V of a three dimensional ferromagnet will be proportional to

- (a) T (b) $T^{3/2}$ (c) $T^{5/2}$ (d) T^3

52. In the semi-empirical mass formula, the volume (V), surface (S), coulomb (C), and pairing (P) contributions to the building energy of a nucleus ${}^A_Z\text{X}$ vary with mass number A as

(a) $V \propto A, S \propto A^{2/3}, C \propto A^{-1/3}, P \propto A^{-3/4}$

(b) $V \propto A, S \propto A^{1/3}, C \propto A^{-1/3}, P \propto A^{-3/4}$

(c) $V \propto A, S \propto A^{-2/3}, C \propto A^{1/3}, P \propto A^{-3/4}$

(d) $V \propto A^2, S \propto A^{2/3}, C \propto A^{-1/3}, P \propto A^{-3/4}$

53. In an experiment, ${}^{197}_{79}\text{Au}$ nuclei were bombarded with neutrons leading to formation of ${}^{198}_{79}\text{Au}$, which is unstable. The half-life of ${}^{198}_{79}\text{Au}$ was measured to be 2.25 days and it was found later that this measured half-life was an underestimate by 10%. The corresponding percentage error in the estimated population of ${}^{198}_{79}\text{Au}$ after 9 days is

- (a) 10% (b) 25% (c) 2.5% (d) 15%



54. You are given the following circuit and two instruments : a voltmeter and an ammeter both with 0.001% accuracy in their readings.

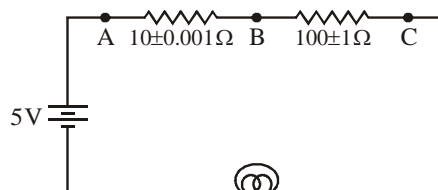

Which of the following methods will result in the most accurate reading for the current without interrupting the current in the circuit ?

- (a) Use voltmeter to measure voltage across points B and C
 (b) Use the ammeter to measure current at point B
 (c) Use voltmeter to measure voltage across points A and B
 (d) Use voltmeter to measure voltage across points A and C
55. Consider the following reaction involving elementary particles:

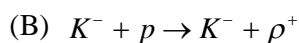
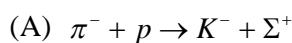

Which of the following statements is true for strong interactions ?

- (a) (A) and (B) are both forbidden (b) (B) is allowed but (A) is forbidden
 (c) (A) is allowed but (B) is forbidden (d) (A) and (B) are both allowed

