



NTA-JOINT CSIR-UGC NET- 2022 (15-02-2022)

PHYSICAL SCIENCES TEST PAPER

## PART - A (General Aptitude)

- At least two among three persons A, B and C are truthful. If A calls B a liar and if B calls C a liar, then which of the following is FALSE ?  
 (a) A is truthful      (b) B is truthful      (c) C is truthful      (d) At least one is a liar
- An intravenous fluid is given to a child of 7.5 kg, at the rate of 20 drop/minute. The prescribed dose of the fluid is 40 ml per kg of body weight. If the volume of a drop is 0.05 ml, how many hours are needed to complete the dose ?  
 (a) 2      (b) 3      (c) 4      (d) 5
- An experiment consists of tossing a coin 20 times. Such an experiment is performed 50 times. The number of heads and the number of tails in each experiment are noted. What is the correlation co-efficient between the two ?  
 (a) -1      (b) -20/50      (c) 20/50      (d) 1
- The arithmetic and geometric means of two numbers are 65 and 25, respectively. What are these two numbers?  
 (a) 110, 20      (b) 115, 15      (c) 120, 10      (d) 125, 5
- An appropriate diagram to represent the relations between the categories KEYBOARD, HARDWARE, OPERATING SYSTEM and CPU is  
 (a)      (b)      (c)      (d)
- Consider a solid cube of side 5 units. After painting, it is cut into cubes of 1 unit. Find the probability that a randomly chosen unit cube has only one side painted.  
 (a) 56/125      (b) 36/125      (c) 44/125      (d) 54/125
- A and B start from the same point in opposite directions along a circular track simultaneously. Speed of B is  $2/3^{\text{rd}}$  that of A. How many times will A and B cross each other before meeting at the starting point ?  
 (a) 2      (b) 3      (c) 5      (d) 4
- A spacecraft flies at a constant height R above a planet of radius R. At the instant the spacecraft is over the north pole, the lowest latitude visible from the spacecraft is:  
 (a)  $0^\circ$  (equator)      (b)  $30^\circ$  N      (c)  $45^\circ$  N      (d)  $60^\circ$  N
- Identical balls are tightly arranged in the shape of an equilateral triangle with each side containing  $n$  balls. How many balls are there in the arrangement?  
 (a)  $n^2/2$       (b)  $n(n+1)/2$       (c)  $n(n-1)/2$       (d)  $(n+1)^2/2$



10. Trade figures and population in appropriate units in a certain year are given for 7 countries.

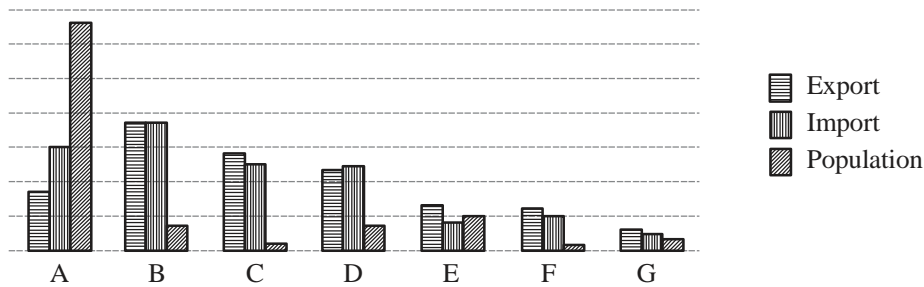

If countries are ranked according to the difference in their per capita exports over import, then the best and worst ranking countries are respectively.

- (a) C and A                      (b) A and E                      (c) C and B                      (d) A and F
11. If we replace the mathematical operations in the expression  $(11 + 4 - 2) \div 24 \times 6$  as given in the table:

|             |   |          |          |        |
|-------------|---|----------|----------|--------|
| Operation   | + | -        | $\times$ | $\div$ |
| Replaced by | - | $\times$ | $\div$   | +      |

then its new value is

- (a)  $23/6$                       (b) 1                      (c) 18                      (d) 7
12. A cylindrical road roller having a diameter of 1.5 m moves at a speed of 3 km/h while levelling a road. How much length of the road will be levelled in 45 minutes ?
- (a) 2.25 km                      (b)  $0.375\pi$  km                      (c)  $0.75\pi$  km                      (d) 1.5 km
13. How many integers in the set  $\{1, 2, 3, \dots, 100\}$  have exactly 3 divisors ?
- (a) 4                      (b) 12                      (c) 5                      (d) 9
14. Which of these groups of numbers has the smallest mean ?
- Group-A: 1, 2, 3, 4, 5, 6, 7, 8, 9  
 Group-B: 1, 2, 3, 4, 6, 6, 7, 8, 9  
 Group-C: 1, 2, 2, 4, 5, 6, 7, 8, 9  
 Group-D: 1, 3, 3, 4, 5, 6, 7, 8, 9
- (a) A                      (b) B                      (c) C                      (d) D
15. The maximum area of a right-angled triangle inscribed in a circle of radius  $r$  is
- (a)  $2r^2$                       (b)  $r^2/2$                       (c)  $\sqrt{2}r^2$                       (d)  $r^2$
16. An inverted cone is filled with water at a constant rate. The volume of water inside the cone as a function of time is represented by the curve

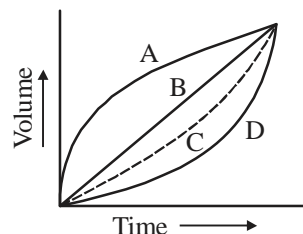

- (a) A                      (b) B                      (c) C                      (d) D
17. In a tournament with 8 teams, a win fetches 3 points and a draw 1. After all teams have played three matches each, total number of points earned by all teams put together must lie between
- (a) 24 and 36                      (b) 24 and 32                      (c) 12 and 24                      (d) 32 and 48

18. Shyam spent half of his money and was left with as many as he had rupees before, but with half as many rupees as he had paise before. Which of the following is a possible amount of money he is left with ?  
 (a) 49 rupees and 98 paise. (b) 49 rupees and 99 paise.  
 (c) 99 rupees and 99 paise. (d) 99 rupees and 98 paise.
19. A shopkeeper has a faulty pan balance with a zero offset. When an object is placed in the left pan it is balanced by a standard 100g weight. When it is placed in the right pan it is balanced by a standard 80g weight. What is the actual weight of the object ?  
 (a) 90 g (b) 88.88 g (c) 95 g (d) 85 g
20. A cousin is a non-sibling with a common ancestor. If there is exactly one pair of siblings in a group of 5 persons then the maximum possible number of pairs of cousins in the group is  
 (a) 3 (b) 6 (c) 9 (d) 10

### PART - B (Physics)

1. The Hamiltonian of a particle of mass  $m$  in one-dimension is  $H = \frac{1}{2m} p^2 + \lambda |x|^3$ ; where  $\lambda > 0$  is a constant. If  $E_1$  and  $E_2$ , respectively, denote the ground-state energies of the particle for  $\lambda = 1$  and  $\lambda = 2$  (in appropriate units) the ratio  $E_2/E_1$  is best approximated by  
 (a) 1.260 (b) 1.414 (c) 1.516 (d) 1.320
2. A particle of mass  $1 \text{ GeV}/c^2$  and its antiparticle, both moving with the same speed  $v$ , produce a new particle  $X$  of mass  $10 \text{ GeV}/c^2$  in a head-on collision. The minimum value of ' $v$ ' required for this process is closest to  
 (a)  $0.83 c$  (b)  $0.93 c$  (c)  $0.98 c$  (d)  $0.88 c$
3. A particle of mass  $m$  is in a one-dimensional infinite potential well of length  $L$ , extending from  $x = 0$  to  $x = L$ . When it is in the energy eigenstate labelled by  $n$ , ( $n = 1, 2, 3, \dots$ ) the probability of finding it in the interval  $0 \leq x \leq (L/8)$  is  $1/8$ . The minimum value of  $n$  for which this is possible is  
 (a) 4 (b) 2 (c) 6 (d) 8
4. A particle in one dimension executes oscillatory motion in a potential  $V(x) = A|x|$ , where  $A > 0$  is a constant of appropriate dimension. If the time period  $T$  of its oscillation depends on the total energy  $E$  as  $E^\alpha$ , then the value of  $\alpha$  is  
 (a)  $1/3$  (b)  $1/2$  (c)  $2/3$  (d)  $3/4$
5. Which of the following two physical quantities cannot be measured simultaneously with arbitrary accuracy for the motion of a quantum particle in three dimensions ?  
 (a) Square of the radial position and  $z$ -component of angular momentum ( $r^2$  and  $L_z$ )  
 (b)  $x$ -components of linear and angular momenta ( $p_x$  and  $L_x$ ).  
 (c)  $y$ -components of position and  $z$ -component of angular momentum ( $y$  and  $L_z$ ).  
 (d) Square of the magnitudes of the linear and angular momenta ( $\mathbf{p}^2$  and  $\mathbf{L}^2$ ).
6. A two-state system evolves under the action of the Hamiltonian  $H = E_0 |A\rangle\langle A| + (E_0 + \Delta) |B\rangle\langle B|$ , where  $|A\rangle$  and  $|B\rangle$  are its two orthonormal states. These states transform to one another under parity i.e.,  $P|A\rangle = |B\rangle$  and  $P|B\rangle = |A\rangle$ . If at time  $t = 0$  the system is in a state of definite parity  $P = 1$ , the earliest time  $t$  at which the probability of finding the system in a state of parity  $P = -1$  is one, is



- (a)  $\frac{\pi\hbar}{2\Delta}$       (b)  $\frac{\pi\hbar}{\Delta}$       (c)  $\frac{3\pi\hbar}{2\Delta}$       (d)  $\frac{2\pi\hbar}{\Delta}$

7. A generic  $3 \times 3$  real matrix  $A$  has eigenvalues 0, 1 and 6, and  $I$  is the  $3 \times 3$  identity matrix. The quantity/quantities that cannot be determined from this information is/are the  
 (a) eigenvalues of  $(I + A)^{-1}$       (b) eigenvalues of  $(I + A^T A)$   
 (c) determinant of  $A^T A$       (d) rank of  $A$
8. In the LCR circuit shown below, the resistance  $R = 0.05 \Omega$ , the inductance  $L = 1$  H and the capacitance  $C = 0.04$  F.

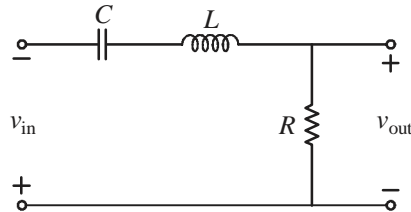

If the input  $v_{in}$  is a square wave of angular frequency 1 rad/sec, the output  $v_{out}$  is best approximated by a

- (a) square wave of angular frequency 1 rad/sec.  
 (b) sine wave of angular frequency 1 rad/sec.  
 (c) square wave of angular frequency 5 rad/sec.  
 (d) sine wave of angular frequency 5 rad/sec.
9. In an experiment, the velocity of a non-relativistic neutron is determined by measuring the time ( $\sim 50$  ns) it takes to travel from the source to the detector kept at a distance  $L$ . Assume that the error in the measurement of  $L$  is negligibly small. If we want to estimate the kinetic energy  $T$  of the neutron to within 5% accuracy, i.e.,  $|\delta T/T| \leq 0.05$ , the maximum permissible error  $|\delta t|$  in measuring the time of flight is nearest to  
 (a) 1.75 ns      (b) 0.75 ns      (c) 2.25 ns      (d) 1.25 ns
10. The door of an X-ray machine room is fitted with a sensor D (0 is open and 1 is closed). It is also equipped with three fire sensors F1, F2 and F3 (each is 0 when disabled and 1 when enabled). The X-ray machine can operate only if the door is closed and at least 2 fire sensors are enabled. The logic circuit to ensure that the machine can be operated is

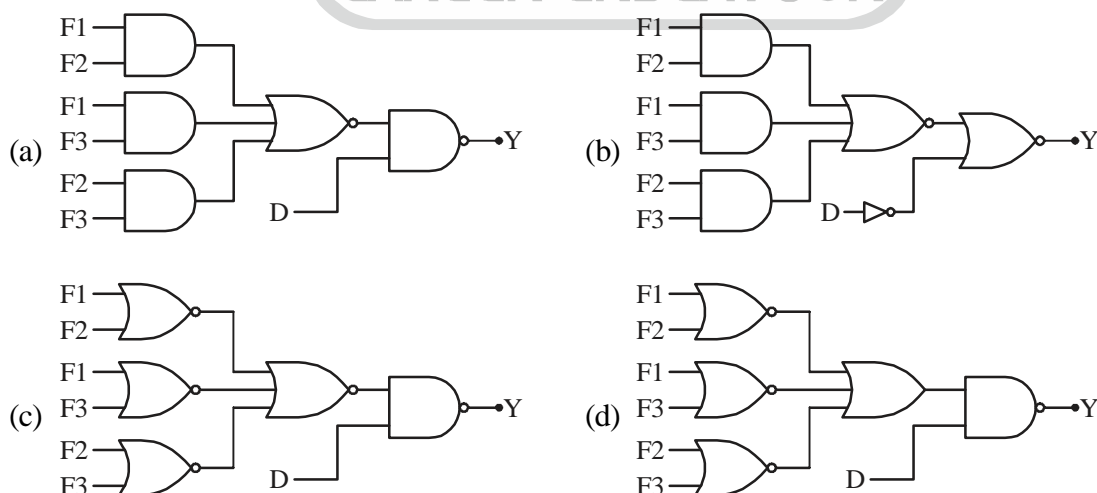

11. A monochromatic source emitting radiation with a certain frequency moves with a velocity  $v$  away from a stationary observer A. It is moving towards another observer B (also at rest) along a line joining the two. The

frequencies of the radiation recorded by  $A$  and  $B$  are  $\nu_A$  and  $\nu_B$ , respectively. If the ratio  $\frac{\nu_B}{\nu_A} = 7$ , then the value of  $\nu/c$  is

- (a)  $\frac{1}{2}$                       (b)  $\frac{1}{4}$                       (c)  $\frac{3}{4}$                       (d)  $\frac{\sqrt{3}}{2}$

12. The ratio  $C_P/C_V$  of the specific heats at constant pressure and volume of a monoatomic ideal gas in two dimension is

- (a)  $3/2$                       (b)  $2$                       (c)  $5/3$                       (d)  $5/2$

13. A discrete random variable  $X$  takes a value from the set  $\{-1, 0, 1, 2\}$  with the corresponding probabilities

$p(X) = \frac{3}{10}, \frac{2}{10}, \frac{2}{10}$  and  $\frac{3}{10}$ , respectively. The probability distribution  $q(Y) = (q(0), q(1), q(4))$  of the random variable  $Y = X^2$  is

- (a)  $\left(\frac{1}{5}, \frac{3}{5}, \frac{1}{5}\right)$                       (b)  $\left(\frac{1}{5}, \frac{1}{2}, \frac{3}{10}\right)$                       (c)  $\left(\frac{2}{5}, \frac{2}{5}, \frac{1}{5}\right)$                       (d)  $\left(\frac{3}{10}, \frac{3}{10}, \frac{2}{5}\right)$

14. The total number of phonon modes in a solid of volume  $V$  is  $\int_0^{\omega_D} g(\omega) d\omega = 3N$ , where  $N$  is the number of primitive cells,  $\omega_D$  is the Debye frequency and density of photon modes is  $g(\omega) = AV\omega^2$  (with  $A > 0$  a constant). If the density of the solid doubles in a phase transition, the Debye temperature  $\theta_D$  will

- (a) increase by a factor of  $2^{2/3}$                       (b) increase by a factor of  $2^{1/3}$   
(c) decrease by a factor of  $2^{2/3}$                       (d) decrease by a factor of  $2^{1/3}$

15. The volume of the region common to the interiors of two infinitely long cylinders defined by  $x^2 + y^2 = 25$  and  $x^2 + 4z^2 = 25$  is best approximated by

- (a) 225                      (b) 333                      (c) 423                      (d) 625

16. In an experiment to measure the charge to mass ratio  $e/m$  of the electron by Thomson's method, the value of the deflecting electric field and the accelerating potential are  $6 \times 10^6$  N/C (Newton per coulomb) and 150 V, respectively. The magnitude of the magnetic field that leads to zero deflection of the electron beam is closest to

- (a) 0.6 T                      (b) 1.2 T                      (c) 0.4 T                      (d) 0.8 T

17. The volume and temperature of a spherical cavity filled with black body radiation are  $V$  and 300 K, respectively. If it expands adiabatically to a volume  $2V$ , its temperature will be closest to

- (a) 150 K                      (b) 300 K                      (c) 250 K                      (d) 240 K

18. A particle, thrown with a speed  $v$  from the earth's surface, attains a maximum height  $h$  (measured from the surface of the earth). If  $v$  is half the escape velocity and  $R$  denotes the radius of earth, then  $h/R$  is

- (a)  $2/3$                       (b)  $1/3$                       (c)  $1/4$                       (d)  $1/2$

19. The vector potential for an almost point like magnetic dipole located at the origin is  $A = \frac{\mu \sin \theta}{4\pi r^2} \hat{\phi}$ , where

$(r, \theta, \phi)$  denote the spherical polar coordinates and  $\hat{\phi}$  is the unit vector along  $\phi$ . A particle of mass  $m$  and charge  $q$ , moving in the equatorial plane of the dipole, starts at time  $t = 0$  with an initial speed  $v_0$  and an impact parameter  $b$ . Its instantaneous speed at the point of closest approach is



- (a)  $v_0$                       (b)  $0/0$                       (c)  $v_0 + \frac{\mu q}{4\pi m b^2}$                       (d)  $\sqrt{v_0^2 + \left(\frac{\mu q}{4\pi m b^2}\right)^2}$

20. A conducting wire in the shape of a circle lies on the  $(x, y)$ -plane, with its centre at the origin. A bar magnet moves with a constant velocity towards the wire along the  $z$ -axis (as shown in the figure below).

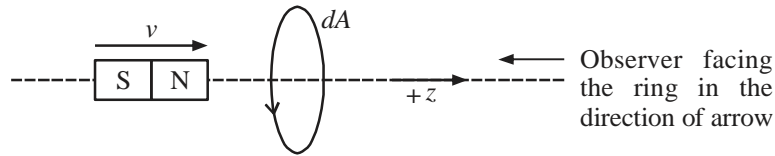

We take  $t = 0$  to be the instant at which the midpoint of the magnet is at the centre of the wire loop and the induced current to be positive when it is counter-clockwise as viewed by the observer facing the loop and the incoming magnet. In these conventions, the best schematic representation of the induced current  $I(t)$  as a function of  $t$ , is

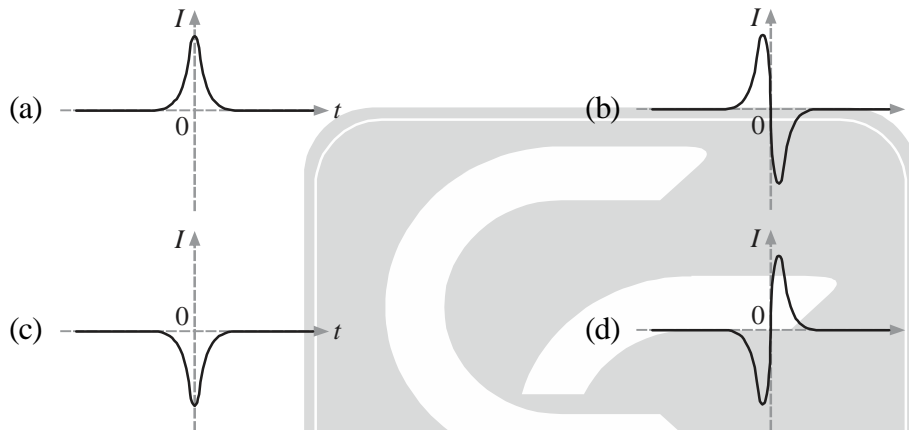

21. The components of the electric field, in a region of space devoid of any charge or current sources, are given to be  $E_i = a_i + \sum_{j=1,2,3} b_{ij} x_j$ , where  $a_i$  and  $b_{ij}$  are constants independent of the coordinates. The number of independent components of the matrix  $b_{ij}$  is

- (a) 5                      (b) 6                      (c) 3                      (d) 4

22. The equation of motion of a one-dimensional forced harmonic oscillator in the presence of a dissipative force is described by  $\frac{d^2x}{dt^2} + 10\frac{dx}{dt} + 16x = 6te^{-8t} + 4t^2 e^{-2t}$ . The general form of the particular solution, in terms of constants  $A, B$  etc., is

- (a)  $t(At^2 + Bt + C)e^{-2t} + (Dt + E)e^{-8t}$                       (b)  $(At^2 + Bt + C)e^{-2t} + (Dt + E)e^{-8t}$   
(c)  $t(At^2 + Bt + C)e^{-2t} + t(Dt + E)e^{-8t}$                       (d)  $(At^2 + Bt + C)e^{-2t} + t(Dt + E)e^{-8t}$

23. The position of a particle in one dimension changes in discrete steps. With each step it moves to the right, however, the length of the step is drawn from a uniform distribution from the interval  $\left[\lambda - \frac{1}{2}w, \lambda + \frac{1}{2}w\right]$ , where  $\lambda$  and  $w$  are positive constants. If  $X$  denotes the distance from the starting point after  $N$  steps, the standard deviation  $\sqrt{\langle X^2 \rangle - \langle X \rangle^2}$  for large values of  $N$  is

(a)  $\frac{\lambda}{2} \times \sqrt{N}$       (b)  $\frac{\lambda}{2} \times \sqrt{\frac{N}{3}}$       (c)  $\frac{w}{2} \times \sqrt{N}$       (d)  $\frac{w}{2} \times \sqrt{\frac{N}{3}}$

24. The figures below depict three different wavefunctions of a particle confined to a one-dimensional box  $-1 \leq x \leq 1$ .

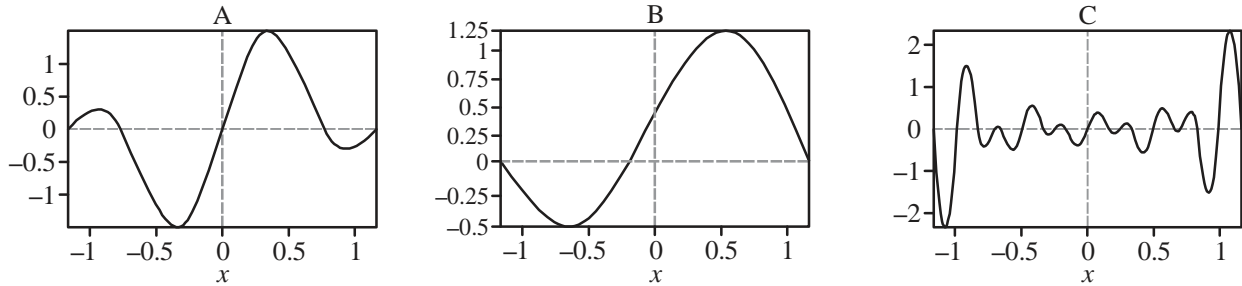

The wavefunctions that correspond to the maximum expectation values  $|\langle x \rangle|$  (absolute value of the mean position) and  $\langle x^2 \rangle$ , respectively, are

- (a) B and C      (b) B and A      (c) C and B      (d) A and B
25. The volume integral  $I = \iiint_V \mathbf{A} \cdot (\nabla \times \mathbf{A}) d^3x$  is over a region  $V$  bounded by a surface  $\Sigma$  (an infinitesimal area element being  $\hat{\mathbf{n}}dS$ , where  $\hat{\mathbf{n}}$  is the outward unit normal). If it changes to  $I + \Delta I$ , when the vector  $\mathbf{A}$  is changed to  $\mathbf{A} + \nabla\Lambda$ , then  $\Delta I$  can be expressed as:

(a)  $\iiint_V \nabla \cdot (\nabla\Lambda \times \mathbf{A}) d^3x$       (b)  $-\iiint_V \nabla^2\Lambda d^3x$   
(c)  $-\oiint_{\Sigma} (\nabla\Lambda \times \mathbf{A}) \cdot \hat{\mathbf{n}}dS$       (d)  $\oiint_{\Sigma} \nabla\Lambda \cdot \hat{\mathbf{n}}dS$

### PART - C (Physics)

1. A particle of mass  $m$  moves in a potential that is  $V = \frac{1}{2} m (\omega_1^2 x^2 + \omega_2^2 y^2 + \omega_3^2 z^2)$  in the coordinates of a non-inertial frame  $F$ . The frame  $F$  is rotating with respect to an inertial frame with an angular velocity  $\hat{\mathbf{k}}\Omega$ , where  $\hat{\mathbf{k}}$  is the unit vector along their common  $z$ -axis. The motion of the particle is unstable for all angular frequencies satisfying
- (a)  $(\Omega^2 - \omega_1^2)(\Omega^2 - \omega_2^2) > 0$       (b)  $(\Omega^2 - \omega_1^2)(\Omega^2 - \omega_2^2) < 0$   
(c)  $(\Omega^2 - (\omega_1 + \omega_2)^2)(\Omega^2 - |\omega_1 - \omega_2|^2) > 0$       (d)  $(\Omega^2 - (\omega_1 + \omega_2)^2)(\Omega^2 - |\omega_1 - \omega_2|^2) < 0$
2. Potassium chloride forms an FCC lattice, in which K and Cl occupy alternating sites. The density of KCl is  $1.98 \text{ g/cm}^3$  and the atomic weights of K and Cl are 39.1 and 35.5, respectively. The angles of incidence (in degrees) for which Bragg peaks will appear when X-ray of wavelength 0.4 nm is shone on a KCl crystal are
- (a) 18.5, 39.4 and 72.2      (b) 19.5 and 41.9  
(c) 12.5, 25.7, 40.5 and 60.0      (d) 13.5, 27.8, 44.5 and 69.0
3. The energies of a two-state quantum system are  $E_0$  and  $E_0 + \alpha\hbar$  (where  $\alpha > 0$  is a constant) and the corresponding normalized state vectors are  $|0\rangle$  and  $|1\rangle$ , respectively. At time  $t = 0$ , when the system is in the state  $|0\rangle$ , the potential is altered by a time independent term  $V$  such that  $\langle 1|V|0\rangle = (\hbar\alpha/10)$ . The transition probability to the state  $|1\rangle$  at times  $t \ll (1/\alpha)$ , is





(a)  $\frac{\alpha^2 t^2}{25}$       (b)  $\frac{\alpha^2 t^2}{50}$       (c)  $\frac{\alpha^2 t^2}{100}$       (d)  $\frac{\alpha^2 t^2}{200}$

4. The Newton-Raphson method is to be used to determine the reciprocal of the number  $x = 4$ . If we start with the initial guess 0.20 then after the first iteration the reciprocal is  
 (a) 0.23      (b) 0.24      (c) 0.25      (d) 0.26
5. A satellite of mass  $m$  orbits around earth in an elliptic trajectory of semi-major axis  $a$ . At a radial distance  $r = r_0$ , measured from the centre of the earth, the kinetic energy is equal to half the magnitude of the total energy. If  $M$  denotes the mass of the earth and the total energy is  $-\frac{GMm}{2a}$ , the value of  $r_0/a$  is nearest to  
 (a) 1.33      (b) 1.48      (c) 1.25      (d) 1.67
6. A laser beam propagates from fiber 1 to fiber 2 in a cavity made up of two optical fibers (as shown in the figure). The loss factor of fiber 2 is 10 dB/km.

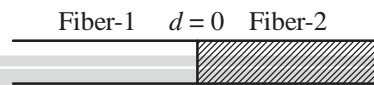

If  $E_2(d)$  denotes the magnitude of the electric field in fiber 2 at a distance  $d$  from the interface, the ratio  $\frac{E_2(0)}{E_2(d)}$  for  $d = 10$  km, is

(a)  $10^2$       (b)  $10^3$       (c)  $10^5$       (d)  $10^7$

7. The  $|3, 0, 0\rangle$  state (in the standard notation  $|n, l, m\rangle$ ) of the H-atom in the non-relativistic theory decays to the state  $|1, 0, 0\rangle$  via two dipole transitions. The transition route and the corresponding probability are  
 (a)  $|3, 0, 0\rangle \rightarrow |2, 1, -1\rangle \rightarrow |1, 0, 0\rangle$  and  $\frac{1}{4}$       (b)  $|3, 0, 0\rangle \rightarrow |2, 1, 1\rangle \rightarrow |1, 0, 0\rangle$  and  $\frac{1}{4}$   
 (c)  $|3, 0, 0\rangle \rightarrow |2, 1, 0\rangle \rightarrow |1, 0, 0\rangle$  and  $\frac{1}{3}$       (d)  $|3, 0, 0\rangle \rightarrow |2, 1, 0\rangle \rightarrow |1, 0, 0\rangle$  and  $\frac{2}{3}$
8. The dispersion relation of a gas of non-interacting bosons in  $d$  dimensions is  $E(k) = ak^s$ , where  $a$  and  $s$  are positive constants. Bose-Einstein condensation will occur for all values of  
 (a)  $d > s$       (b)  $d + 2 > s > d - 2$   
 (c)  $s > 2$  independent of  $d$       (d)  $d > 2$  independent of  $s$
9. A linear diatomic molecule consists of two identical small electric dipoles with an equilibrium separation  $R$ , which is assumed to be a constant. Each dipole has charges  $+q$  of mass  $m$  separated by  $r$  when the molecule is at equilibrium. Each dipole can execute simple harmonic motion of angular frequency  $\omega$ .

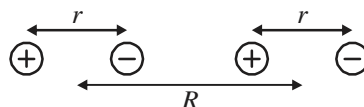

Recall that the interaction potential between two dipoles of moments  $\mathbf{p}_1$  and  $\mathbf{p}_2$ , separated by  $\mathbf{R}_{12} = R_{12}\hat{n}$  is  $(\mathbf{p}_1 \cdot \mathbf{p}_2 - 3(\mathbf{p}_1 \cdot \hat{n})(\mathbf{p}_2 \cdot \hat{n})) / (4\pi \epsilon_0 R_{12}^3)$ .



Assume that  $R \gg r$  and let  $\Omega^2 = \frac{q^2}{4\pi \epsilon_0 mR^3}$ . The angular frequencies of small oscillations of the diatomic molecule are

- (a)  $\sqrt{\omega^2 + \Omega^2}$  and  $\sqrt{\omega^2 - \Omega^2}$                       (b)  $\sqrt{\omega^2 + 3\Omega^2}$  and  $\sqrt{\omega^2 - 3\Omega^2}$   
 (c)  $\sqrt{\omega^2 + 4\Omega^2}$  and  $\sqrt{\omega^2 - 4\Omega^2}$                       (d)  $\sqrt{\omega^2 + 2\Omega^2}$  and  $\sqrt{\omega^2 - 2\Omega^2}$

10. In the reaction  $p + n \rightarrow p + K^+ + X$ , mediated by strong interaction, the baryon number  $B$ , strangeness  $S$  and the third component of isospin  $I_3$  of the particle  $X$  are, respectively.  
 (a)  $-1, -1$  and  $-1$       (b)  $+1, -1$  and  $-1$       (c)  $+1, -2$  and  $-1/2$       (d)  $-1, -1$  and  $0$
11. The pressure of a gas in a vessel needs be maintained between 1.5 bar to 2.5 bar in an experiment. The vessel is fitted with a pressure transducer that generates 4 mA to 20 mA current for pressure in the range 1 bar to 5 bar. The current output of the transducer has a linear dependence on the pressure.

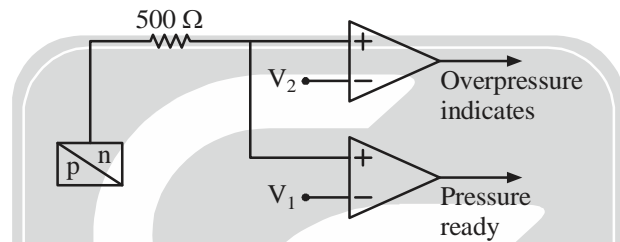

The reference voltage  $V_1$  and  $V_2$  in the comparators in the circuit (shown in figure above) suitable for the desired operating conditions are, respectively

- (a) 2 V and 10 V      (b) 2 V and 5 V      (c) 3 V and 10 V      (d) 3 V and 5 V
12. A  $^{60}\text{Co}$  nucleus  $\beta$ -decays from its ground state with  $J^P = 5^+$  to a state of  $^{60}\text{Ni}$  with  $J^P = 4^+$ . From the angular momentum selection rules, the allowed values of the orbital angular momentum  $L$  and the total spin  $S$  of the electron-antineutrino pair are  
 (a)  $L = 0$  and  $S = 1$       (b)  $L = 1$  and  $S = 0$       (c)  $L = 0$  and  $S = 0$       (d)  $L = 1$  and  $S = 1$
13. Diffuse hydrogen gas within a galaxy may be assumed to follow a Maxwell distribution at temperature  $10^6$  K, while the temperature appropriate for the H gas in the inter-galactic space, following the same distribution, may be taken to be  $10^4$  K. The ratio of thermal broadening  $\Delta v_G / \Delta v_{IG}$  of the Lyman- $\alpha$  line from the H-atoms within the galaxy to that from the inter-galactic space is closest to  
 (a) 100      (b) 1/100      (c) 10      (d) 1/10
14. A polymer made up of  $N$  monomers, is in thermal equilibrium at temperature  $T$ . Each monomer could be of length  $a$  or  $2a$ . The first contributes zero energy, while the second one contributes  $\epsilon$ . The average length (in units of  $Na$ ) of the polymer at temperature  $T = (\epsilon/k_B)$  is  
 (a)  $\frac{5+e}{4+e}$       (b)  $\frac{4+e}{3+e}$       (c)  $\frac{3+e}{2+e}$       (d)  $\frac{2+e}{1+e}$
15. A perfectly conducting fluid, of permittivity  $\epsilon$  and permeability  $\mu$ , flows with a uniform velocity  $v$  in the presence of time dependent electric and magnetic fields  $\mathbf{E}$  and  $\mathbf{B}$ , respectively. If there is a finite current density in the fluid, then

$$(a) \nabla \times (\mathbf{v} \times \mathbf{B}) = \frac{\partial \mathbf{B}}{\partial t} \quad (b) \nabla \times (\mathbf{v} \times \mathbf{B}) = -\frac{\partial \mathbf{B}}{\partial t}$$

$$(c) \nabla \times (\mathbf{v} \times \mathbf{B}) = \sqrt{\varepsilon\mu} \frac{\partial \mathbf{E}}{\partial t} \quad (d) \nabla \times (\mathbf{v} \times \mathbf{B}) = -\sqrt{\varepsilon\mu} \frac{\partial \mathbf{E}}{\partial t}$$

16. The energy levels of a non-degenerate quantum system are  $\varepsilon_n = nE_0$ , where  $E_0$  is a constant and  $n = 1, 2, 3, \dots$ . At a temperature  $T$ , the free energy  $F$  can be expressed in terms of the average energy  $E$  by

$$(a) E_0 + k_B T \ln \frac{E}{E_0} \quad (b) E_0 + 2k_B T \ln \frac{E}{E_0} \quad (c) E_0 - k_B T \ln \frac{E}{E_0} \quad (d) E_0 - 2k_B T \ln \frac{E}{E_0}$$

17. The unnormalized wavefunction of a particle in one dimension in an infinite square well with walls at  $x = 0$  and  $x = a$ , is  $\psi(x) = x(a - x)$ . If  $\psi(x)$  is expanded as a linear combination of the energy eigenfunctions,

$\int_0^a |\psi(x)|^2 dx$  is proportional to the infinite series

[You may use:  $\int_0^a t \sin t dt = -a \cos a + \sin a$  and  $\int_0^a t^2 \sin t dt = -2 - (a^2 - 2) \cos a + 2a \sin a$ ]

$$(a) \sum_{n=1}^{\infty} (2n-1)^{-6} \quad (b) \sum_{n=1}^{\infty} (2n-1)^{-4} \quad (c) \sum_{n=1}^{\infty} (2n-1)^{-2} \quad (d) \sum_{n=1}^{\infty} (2n-1)^{-8}$$

18. The Legendre polynomials  $P_n(x)$ ,  $n = 0, 1, 2, \dots$ , satisfying the orthogonality condition

$$\int_{-1}^1 P_n(x) P_m(x) dx = \frac{2}{2n+1} \delta_{nm} \text{ on the interval } [-1, +1], \text{ may be defined by the Rodrigues formula}$$

$$P_n(x) = \frac{1}{2^n n!} \frac{d^n}{dx^n} (x^2 - 1)^n. \text{ The value of the definite integral } \int_{-1}^1 (4 + 2x - 3x^2 + 4x^3) P_3(x) dx \text{ is}$$

$$(a) 3/5 \quad (b) 11/15 \quad (c) 23/32 \quad (d) 16/35$$

19. The figure below shows an ideal capacitor consisting of two parallel circular plates of radius  $R$ . Points  $P_1$  and  $P_2$  are at a transverse distance  $r_1 > R$  from the line joining the centres of the plates, while points  $P_3$  and  $P_4$  are at a transverse distance  $r_2 < R$ .

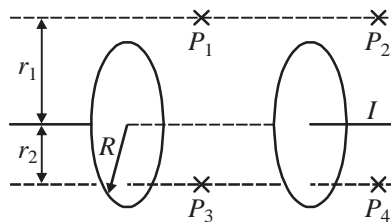

If  $B(x)$  denotes the magnitude of the magnetic fields at these points, which of the following holds while the capacitor is charging?

$$(a) B(P_1) < B(P_2) \text{ and } B(P_3) < B(P_4) \quad (b) B(P_1) > B(P_2) \text{ and } B(P_3) > B(P_4)$$

$$(c) B(P_1) = B(P_2) \text{ and } B(P_3) < B(P_4) \quad (d) B(P_1) = B(P_2) \text{ and } B(P_3) > B(P_4)$$

20. Balls of ten different colours labeled by  $a = 1, 2, \dots, 10$  are to be distributed among different coloured boxes. A ball can only go in a box of the same colour, and each box can contain at most one ball. Let  $n_a$  and  $N_a$  denote, respectively, the numbers of balls and boxes of colour  $a$ . Assuming that  $N_a \gg n_a \gg 1$ , the total entropy (in units of the Boltzmann constant) can be best approximated by



- (a)  $\sum_a (N_a \ln N_a + n_a \ln n_a - (N_a - n_a) \ln (N_a - n_a))$   
 (b)  $\sum_a (N_a \ln N_a - n_a \ln n_a - (N_a - n_a) \ln (N_a - n_a))$   
 (c)  $\sum_a (N_a \ln N_a - n_a \ln n_a + (N_a - n_a) \ln (N_a - n_a))$   
 (d)  $\sum_a (N_a \ln N_a + n_a \ln n_a + (N_a - n_a) \ln (N_a - n_a))$

21. To measure the height  $h$  of a column of liquid helium in a container, a constant current  $I$  is sent through an NbTi wire of length  $l$ , as shown in the figure. The normal state resistance of the NbTi wire is  $R$ .

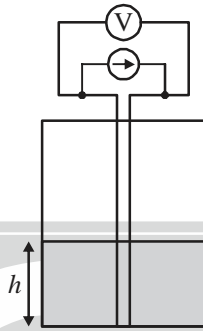

If the superconducting transition temperature of NbTi is  $\approx 10$  K, then the measured voltage  $V(h)$  is best described by the expression.

- (a)  $IR\left(\frac{1}{2} - \frac{2h}{l}\right)$     (b)  $IR\left(1 - \frac{h}{l}\right)$     (c)  $IR\left(\frac{1}{2} - \frac{h}{l}\right)$     (d)  $IR\left(1 - \frac{2h}{l}\right)$

22. A particle of mass  $m$  in one dimension is in the ground state of a simple harmonic oscillator described by a

Hamiltonian  $H = \frac{p^2}{2m} + \frac{1}{2}m\omega^2 x^2$  in the standard notation. An impulsive force at time  $t=0$  suddenly imparts

a momentum  $p_0 = \sqrt{\hbar m \omega}$  to it. The probability that the particle remains in the original ground state is

- (a)  $e^{-2}$     (b)  $e^{-3/2}$     (c)  $e^{-1}$     (d)  $e^{-1/2}$

23. A particle in two dimensions is found to trace an orbit  $r(\theta) = r_0 \theta^2$ . If it is moving under the influence of a

central potential  $V(r) = c_1 r^{-a} + c_2 r^{-b}$ , where  $r_0, c_1$  and  $c_2$  are constants of appropriate dimensions, the values of 'a' and 'b', respectively, are

- (a) 2 and 4    (b) 2 and 3    (c) 3 and 4    (d) 1 and 3

24. In the following circuit the input voltage  $V_{in}$  is such that  $|V_{in}| < |V_{sat}|$ , where  $V_{sat}$  is the saturation voltage of the op-amp. (Assume that the diode is an ideal one and  $R_L C$  is much larger than the duration of the measurement)

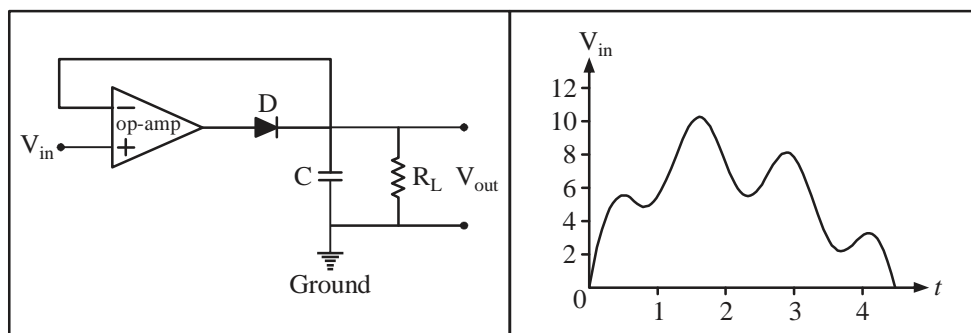

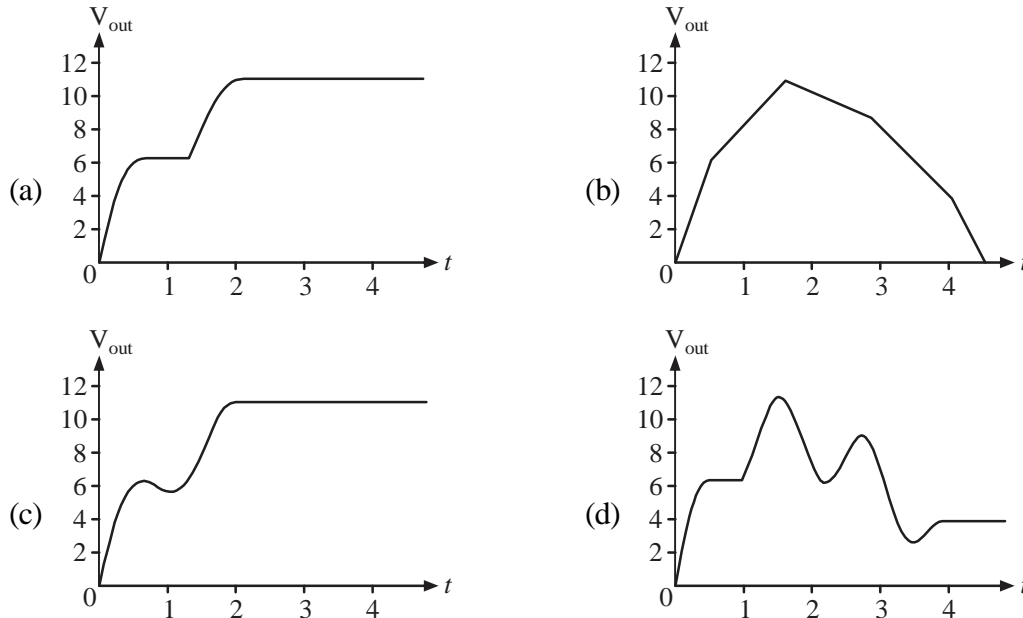

25. Lead is superconducting below 7 K and has a critical magnetic field  $800 \times 10^{-4}$  Tesla close to 0 K. At 2 K the critical current that flows through a long lead wire of radius 5 mm is closest to  
 (a) 1760 A                      (b) 1670 A                      (c) 1950 A                      (d) 1840 A

26. If we use the Fourier transform  $\phi(x, y) = \int e^{ikx} \phi_k(y) dk$  to solve the partial differential equation:

$$-\frac{\partial^2 \phi(x, y)}{\partial y^2} - \frac{1}{y^2} \frac{\partial^2 \phi(x, y)}{\partial x^2} + \frac{m^2}{y^2} \phi(x, y) = 0$$

in the half-plane  $\{(x, y) : -\infty < x < \infty, 0 < y < \infty\}$  the Fourier modes  $\phi_k(y)$  depend on  $y$  as  $y^\alpha$  and  $y^\beta$ . The values of  $\alpha$  and  $\beta$  are

- (a)  $\frac{1}{2} + \sqrt{1 + 4(k^2 + m^2)}$  and  $\frac{1}{2} - \sqrt{1 + 4(k^2 + m^2)}$   
 (b)  $1 + \sqrt{1 + 4(k^2 + m^2)}$  and  $1 - \sqrt{1 + 4(k^2 + m^2)}$   
 (c)  $\frac{1}{2} + \frac{1}{2} \sqrt{1 + 4(k^2 + m^2)}$  and  $\frac{1}{2} - \frac{1}{2} \sqrt{1 + 4(k^2 + m^2)}$   
 (d)  $1 + \frac{1}{2} \sqrt{1 + 4(k^2 + m^2)}$  and  $1 - \frac{1}{2} \sqrt{1 + 4(k^2 + m^2)}$
27. The fulcrum of a simple pendulum (consisting of a particle of mass  $m$  attached to the support by a massless string of length  $l$ ) oscillates vertically as  $\sin z(t) = a \sin \omega t$ , where  $\omega$  is a constant. The pendulum moves in a vertical plane and  $\theta(t)$  denotes its angular position with respect to the  $z$ -axis.

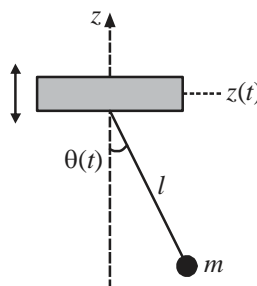

If  $l \frac{d^2\theta}{dt^2} + \sin\theta (g - f(t)) = 0$ , (where  $g$  is the acceleration due to gravity) describes the equation of motion of the mass, then  $f(t)$  is

- (a)  $a\omega^2 \cos \omega t$       (b)  $a\omega^2 \sin \omega t$       (c)  $-a\omega^2 \cos \omega t$       (d)  $-a\omega^2 \sin \omega t$

28. The  $Q$ -value of the  $\alpha$ -decay of  $^{232}\text{Th}$  to the ground state of  $^{228}\text{Ra}$  is 4082 keV. The maximum possible kinetic energy of the  $\alpha$ -particle is closest to  
(a) 4082 keV      (b) 4050 keV      (c) 4035 keV      (d) 4012 keV
29. The nuclei of  $^{137}\text{Cs}$  decay by the emission of  $\beta$ -particles with a half-life of 30.08 years. The activity (in units of disintegrations per second or Bq) of a 1 mg source of  $^{137}\text{Cs}$ , prepared on January 1, 1980, as measured on January 1, 2021 is closest to  
(a)  $1.79 \times 10^{16}$       (b)  $1.79 \times 10^9$       (c)  $1.24 \times 10^{16}$       (d)  $1.24 \times 10^9$
30. In an elastic scattering process at an energy  $E$ , the phase shifts satisfy  $\delta_0 \approx 30^\circ$ ,  $\delta_1 \approx 10^\circ$ , while the other phase shifts are zero. The polar angle at which the differential cross-section peaks is closest to  
(a)  $20^\circ$       (b)  $10^\circ$       (c)  $0^\circ$       (d)  $30^\circ$

\*\*\*\*\* End of Question Paper \*\*\*\*\*

