



PART-A : MULTIPLE CHOICE QUESTIONS (MCQ)

Q.1 To Q.10 : Each carry ONE mark

1. A projectile of mass m is moving in the vertical xy -plane with the origin on the ground and y -axis pointing vertically up. Taking the gravitational potential energy to be zero on the ground, the total energy of the particle written in planar polar coordinates (r, θ) is (here g is the acceleration due to gravity)

- (a) $\frac{m}{2}(\dot{r}^2 + r^2\dot{\theta}^2) - mgr \cos \theta$ (b) $\frac{m}{2}(\dot{r}^2 + r^2\dot{\theta}^2) + mgr \sin \theta$
 (c) $\frac{m}{2}\dot{r}^2 + mgr \sin \theta$ (d) $\frac{m}{2}(\dot{r}^2 + r^2\dot{\theta}^2) + mgr \cos \theta$

2. In the given circuit, with an ideal op-amp for what value of R_1/R_2 the output of the amplifier $V_{out} = V_2 - V_1$?

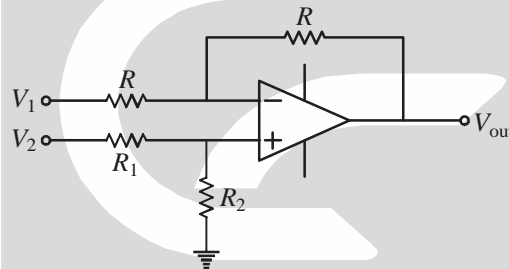

- (a) 1 (b) 1/2 (c) 2 (d) 3/2
3. For the following circuit, choose the correct waveform corresponding to the output signal (V_{out}). Given $V_{in} = 5 \sin(200\pi t)$ V, forward bias voltage of the diodes (D and Z) = 0.7 V and reverse Zener voltage = 3V.

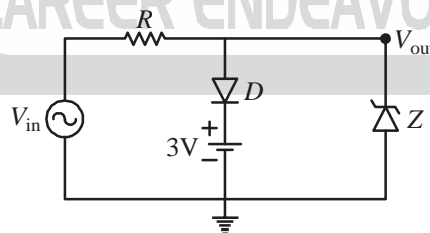

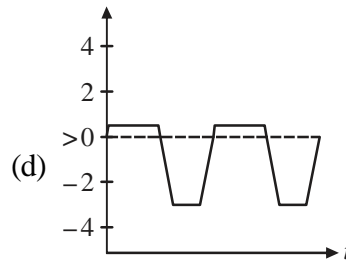
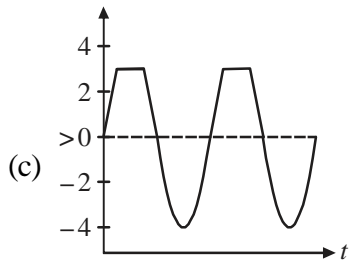

4. Temperature (T) dependence of the total specific heat (C_V) for a two dimensional metallic solid at low temperature is

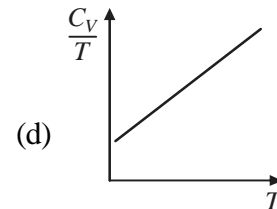
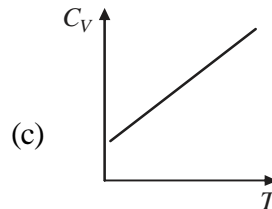
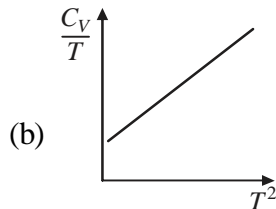
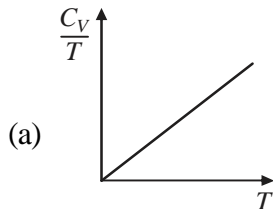

5. A system has N spins, where each spin is capable of existing in 4 possible states. The difference in entropy of disordered states (where all possible spin configurations are equally probable) and ordered states is

(a) $4k_B \ln N$ (b) $Nk_B \ln 2$ (c) $2(N-1)k_B \ln 2$ (d) $(N-1)k_B \ln 2$

6. Which of the following fields has non-zero curl ?

(a) $y^2 \hat{i} + (2xy + z^2) \hat{j} + 2yz \hat{k}$ (b) $xy \hat{i} + 2yz \hat{j} + 3xz \hat{k}$

(c) $(y+z) \hat{i} + (x+z) \hat{j} + (x+y) \hat{k}$ (d) $x \hat{i} + y \hat{j} + z \hat{k}$

7. If the ground state energy of a particle in an infinite potential well of width L_1 is equal to the energy of the second excited state in another infinite potential well of width L_2 , the ratio L_1/L_2 is equal to

(a) 1 (b) 1/9 (c) $1/\sqrt{3}$ (d) 1/3

8. The plot of the function $f(x) = ||x| - 1|$ is

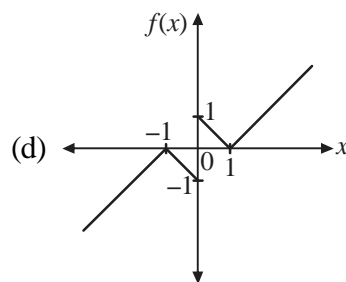
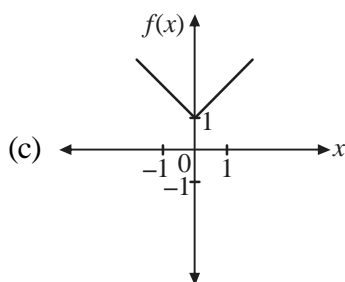
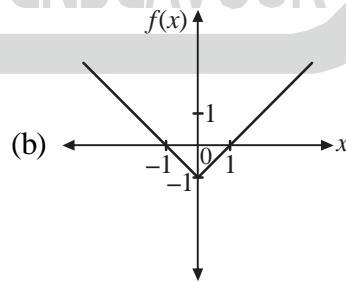
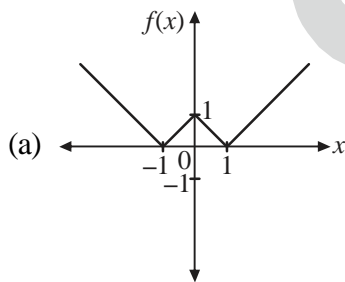

9. Which of the following statements about the viscosity of a dilute ideal gas is *correct* ?
- It is independent of pressure at fixed temperature.
 - It decrease with increasing temperature.
 - It is independent of temperature.
 - It increases with increasing pressure at fixed temperature.
10. For a cubic unit cell, the dashed arrow in which of the following figures represents the direction [220] ?

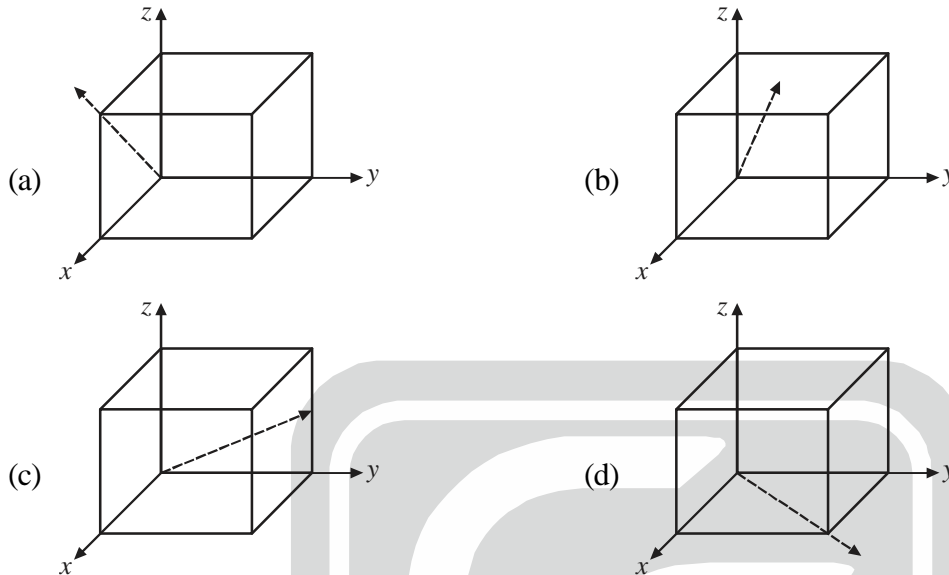

Q.11 To Q.30 : Each carry TWO marks

11. At the planar interface of two dielectrics, which of the following statements related to the electric field (\vec{E}), electric displacement (\vec{D}) and polarization (\vec{P}) is true ?
- Normal component of \vec{D} is continuous and that of \vec{P} is discontinuous.
 - Normal component of both \vec{E} and \vec{P} are continuous.
 - Normal component of both \vec{D} and \vec{E} are discontinuous.
 - Normal component of both \vec{D} and \vec{P} are continuous.
12. A rotating disc is held in front of a plane mirror in two different orientations which are (i) angular momentum parallel to the mirror and (ii) angular momentum perpendicular to the mirror. Which of the following schematic figures correctly describes the angular momentum (solid arrow) and its mirror image (shown by dashed arrows) in the two orientations ?

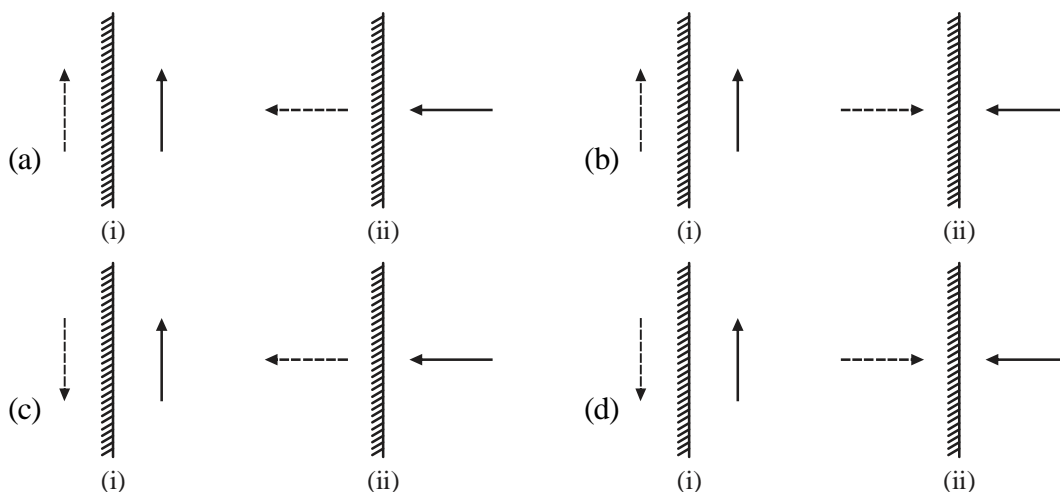

13. Consider a system of large number of particles that can be in three energy states with energy 0 meV, 1 meV and 2 meV. At temperature $T = 300$ K, the mean energy of the system (in meV) is closest to
Given: Boltzmann constant $k_B = 0.086$ meV-K⁻¹.
- (a) 0.12 (b) 0.97 (c) 1.32 (d) 1.82

14. For a given vector $\vec{F} = -y\hat{i} + z\hat{j} + x^2\hat{k}$, the surface integral $\int_S (\vec{\nabla} \times \vec{F}) \cdot \hat{n} dS$ over the surface S of a hemisphere of radius R with the centre of the base at the origin is

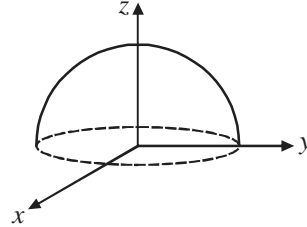

- (a) $\frac{2\pi R^2}{3}$ (b) $-\pi R^2$ (c) $-\frac{2\pi R^2}{3}$ (d) πR^2
15. The Jacobian matrix for transforming from (x, y) to another orthogonal coordinates system (u, v) as shown in the figure is

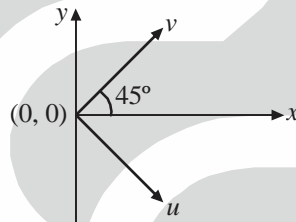

- (a) $\frac{1}{\sqrt{2}} \begin{bmatrix} 1 & 1 \\ -1 & 1 \end{bmatrix}$ (b) $\frac{1}{\sqrt{2}} \begin{bmatrix} 1 & 1 \\ 1 & -1 \end{bmatrix}$ (c) $\frac{1}{\sqrt{2}} \begin{bmatrix} 1 & -1 \\ 1 & -1 \end{bmatrix}$ (d) $\frac{1}{\sqrt{2}} \begin{bmatrix} 1 & -1 \\ 1 & 1 \end{bmatrix}$
16. In a dielectric medium of relative permittivity 5, the amplitude of the displacement current and conduction current are equal for an applied sinusoidal voltage of frequency $f = 1$ MHz. The value of conductivity (in $\Omega^{-1} \text{ m}^{-1}$) of the medium at this frequency is
- (a) 2.44×10^{-4} (b) 2.78×10^{-3} (c) 2.44×10^{-3} (d) 2.78×10^{-4}

17. Inverse of the matrix $\begin{bmatrix} 1 & 1 & 0 \\ 2 & 3 & 0 \\ 1 & 0 & 1 \end{bmatrix}$ is

(a) $\begin{bmatrix} -1 & -1 & 0 \\ 2 & 3 & 0 \\ 1 & 0 & 1 \end{bmatrix}$ (b) $\begin{bmatrix} 3 & -2 & -3 \\ -2 & 1 & 1 \\ 0 & 0 & 1 \end{bmatrix}$ (c) $\begin{bmatrix} 3 & -1 & 0 \\ -2 & 1 & 0 \\ -3 & 1 & 1 \end{bmatrix}$ (d) $\begin{bmatrix} 1 & -2 & 1 \\ -1 & 3 & 0 \\ 0 & 0 & 1 \end{bmatrix}$

18. Suppose the divergence of magnetic field \vec{B} is non-zero and is given as $\vec{\nabla} \cdot \vec{B} = \mu_0 \rho_m$, where μ_0 is the permeability of vacuum and ρ_m is the magnetic charge density. If the corresponding magnetic current density is \vec{J}_m , then the curl $\vec{\nabla} \times \vec{E}$ of the electric \vec{E} is

(a) $-\mu_0 \vec{J}_m - \frac{\partial \vec{B}}{\partial t}$ (b) $\vec{J}_m - \frac{\partial \vec{B}}{\partial t}$ (c) $-\vec{J}_m - \frac{\partial \vec{B}}{\partial t}$ (d) $\mu_0 \vec{J}_m - \frac{\partial \vec{B}}{\partial t}$

19. A small bar magnet is dropped through different hollow copper tubes with same length and inner diameter but with different outer diameter. The variation in the time (t) taken for the magnet to reach the bottom of the tube depends on its wall thickness (d) as

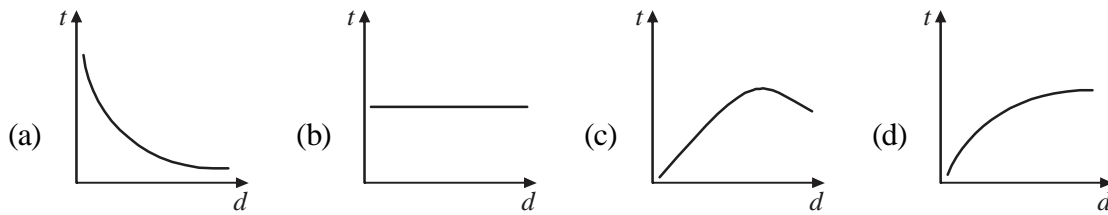

20. A container is occupied by a fixed number of non-interacting particles. If they are obeying Fermi-Dirac, Bose-Einstein and Maxwell-Boltzmann statistics, the pressure in the container is P_{FD} , P_{BE} and P_{MB} , respectively. Then,

(a) $P_{FD} = P_{MB} = P_{BE}$ (b) $P_{FD} > P_{MB} > P_{BE}$ (c) $P_{FD} > P_{BE} > P_{MB}$ (d) $P_{FD} > P_{MB} = P_{BE}$

21. Water from a tank is flowing down through a hole at its bottom with velocity 5 ms^{-1} . If this water falls on a flat surface kept below the hole at a distance of 0.1 m and spreads horizontally, the pressure (in kNm^{-2}) exerted on the flat surface is closest to

[Given: Acceleration due to gravity = 9.8 ms^{-2} and density of water = 1000 kgm^{-3}]

(a) 27.0 (b) 6.8 (c) 13.5 (d) 17.6

22. For the Maxwell-Boltzmann speed distribution, the ratio of the root-mean-square speed ($v_{\text{r.m.s.}}$) and the most probable speed (v_{max}) is

Given: Maxwell-Boltzmann speed distribution function for a collection of particles of mass m is

$$f(v) = \left(\frac{m}{2\pi k_B T} \right)^{3/2} 4\pi v^2 \exp\left(-\frac{mv^2}{2k_B T} \right)$$

where, v is the speed and $k_B T$ is the thermal energy.

(a) $\frac{3}{2}$ (b) $\sqrt{\frac{2}{3}}$ (c) $\sqrt{\frac{3}{2}}$ (d) $\frac{2}{3}$

23. For a thermodynamic system, the coefficient of volume expansion $\beta = \frac{1}{V} \left(\frac{\partial V}{\partial T} \right)_P$ and compressibility

$\kappa = -\frac{1}{V} \left(\frac{\partial V}{\partial P} \right)_T$, where V , T , and P are respectively the volume, temperature, and pressure. Considering that

$\frac{dV}{V}$ is a perfect differential, we get,

(a) $\left(\frac{\partial \beta}{\partial P} \right)_T = \left(\frac{\partial \kappa}{\partial T} \right)_P$ (b) $\left(\frac{\partial \beta}{\partial T} \right)_P = -\left(\frac{\partial \kappa}{\partial P} \right)_T$
 (c) $\left(\frac{\partial \beta}{\partial P} \right)_T = -\left(\frac{\partial \kappa}{\partial T} \right)_P$ (d) $\left(\frac{\partial \beta}{\partial T} \right)_P = \left(\frac{\partial \kappa}{\partial P} \right)_T$



24. A linearly polarized light of wavelength 590 nm is incident normally on the surface of a 20 μm thick quartz film. The plane of polarization makes an angle 30° with the optic axis. Refractive indices of ordinary and extraordinary waves differ by 0.0091, resulting in a phase difference of $f\pi$ between them after transmission. The value of f (rounded off to two decimal places) and the state of polarization of the transmitted light is
 (a) -0.38 and elliptical (b) 0.62 and elliptical (c) 0.5 and circular (d) 0.62 and linear

25. Two digital inputs A and B are given to the following circuit. For $A = 1, B = 0$, the values of X and Y are:

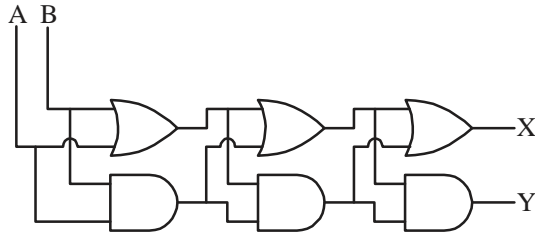

- (a) $X = 0, Y = 1$ (b) $X = 1, Y = 1$ (c) $X = 1, Y = 0$ (d) $X = 0, Y = 0$
26. The phase velocity v_p of transverse waves on a one-dimensional crystal of atomic separation d is related to the wave-vector k as

$$v_p = C \frac{\sin(kd/2)}{(kd/2)}$$

The group velocity of these waves is

- (a) $C \frac{\sin(kd/2)}{(kd/2)}$ (b) $C \left[\cos(kd/2) - \frac{\sin(kd/2)}{(kd/2)} \right]$
 (c) $C \left[\cos(kd/2) + \frac{\sin(kd/2)}{(kd/2)} \right]$ (d) $C \cos(kd/2)$
27. An oil film in air of thickness 255 nm is illuminated by white light at normal incidence. As a consequence of interference, which colour will be predominantly visible in the reflected light ?
 Given the refractive index of oil = 1.47
 (a) Blue (~ 450 nm) (b) Red (~ 650 nm) (c) Yellow (~ 560 nm) (d) Green (~ 500 nm)
28. In the circuit shown, assuming the current gain $\beta = 100$ and $V_{BE} = 0.7$ V, what will be the collector voltage V_C in V ? [Given: $V_{CC} = 15$ V, $R_1 = 100$ k Ω , $R_2 = 50$ k Ω , $R_C = 4.7$ k Ω and $R_E = 3.3$ k Ω]

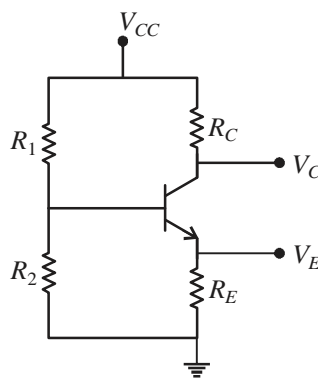

- (a) 8.9 (b) 3.2 (c) 4.3 (d) 5.1

29. A uniform stick of length l and mass m pivoted at its top end is oscillating with an angular frequency ω_r . Assuming small oscillations, the ratio ω_r/ω_s , where ω_s is the angular frequency of a simple pendulum of the same length will be

- (a) $\sqrt{3}$ (b) $\sqrt{\frac{3}{2}}$ (c) $\frac{1}{\sqrt{3}}$ (d) $\sqrt{2}$

30. In an extrinsic p -type semiconductor, which of the following schematic diagram depicts the variation of the Fermi energy level (E_F) with temperature (T) ?

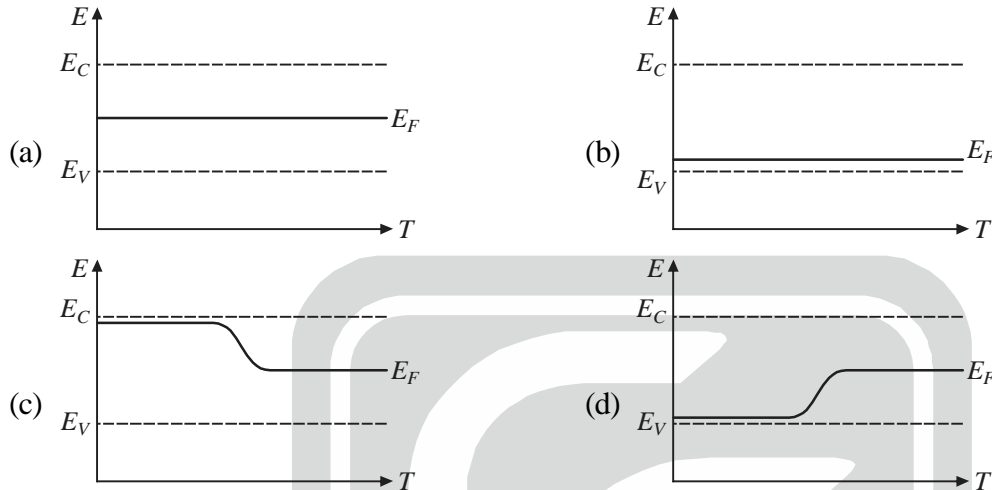

PART-B : MULTIPLE SELECTIVE QUESTIONS (MSQ)

Q.31 To Q.40 : Each carry TWO marks

31. For a particle moving in a general central force field, which of the following statement(s) is/are TRUE ?
 (a) Kepler's third law is valid (b) Kepler's second law is valid.
 (c) The motion is confined to a plane (d) The angular momentum is a constant of motion.
32. An objective lens with half angular aperture α is illuminated with light of wavelength λ . The refractive index of the medium between the sample and the objective is n . The lateral resolving power of the optical system can be increased by

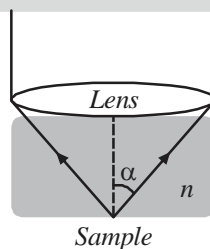

- (a) decreasing λ and increasing n (b) increasing both α and n
 (c) decreasing both λ and α (d) decreasing λ and increasing α

33. Which of the following schematic plots correctly represent(s) a first order phase transition occurring at temperature $T = T_C$? [Here g , s , v are specific Gibbs free energy, entropy and volume, respectively.]

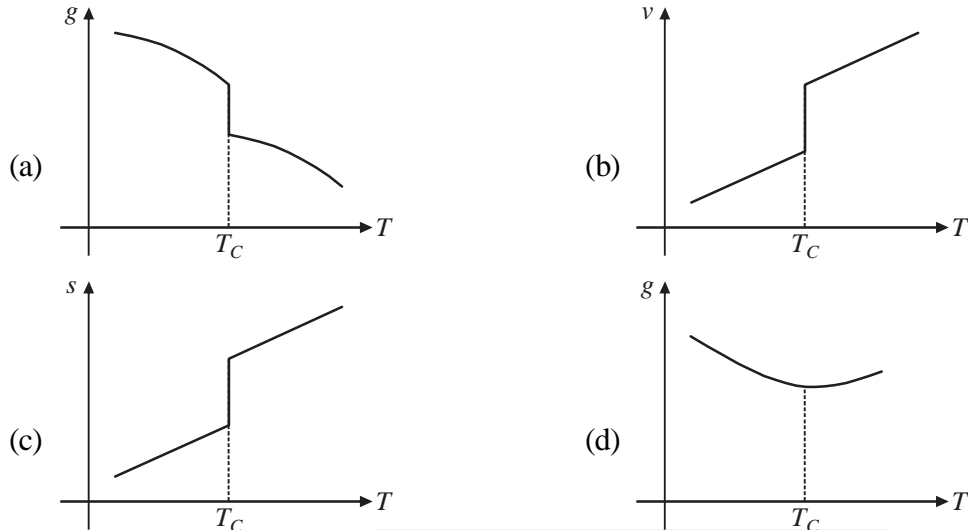

34. A wave travelling along the x -axis with y representing its displacement is described by (v is the speed of the wave)

(a) $\frac{\partial^2 y}{\partial x^2} - \frac{1}{v^2} \frac{\partial^2 y}{\partial t^2} = 0$ (b) $\frac{\partial^2 y}{\partial x^2} + \frac{1}{v^2} \frac{\partial^2 y}{\partial t^2} = 0$

(c) $\frac{\partial y}{\partial x} - \frac{1}{v} \frac{\partial y}{\partial t} = 0$ (d) $\frac{\partial y}{\partial x} + \frac{1}{v} \frac{\partial y}{\partial t} = 0$

35. A particle (p_1) of mass m moving with speed v collides with a stationary identical particle (p_2). The particles bounce off each other elastically with p_1 getting deflected by an angle $\theta = 30^\circ$ from its original direction. Then, which of the following statement(s) is/are true after the collision?

- (a) Angle between the directions of motion of the two particles is 90° .
- (b) Speed of p_1 is $\frac{\sqrt{3}}{2}v$.
- (c) Kinetic energy of p_2 is 25 % of the total energy.
- (d) The kinetic energy of the centre of mass p_1 and p_2 decreases.

36. A periodic functions $f(x) = x^2$ for $-\pi < x < \pi$ is expanded in a Fourier series. Which of the following statement(s) is/are **correct**?

- (a) Coefficient of all the sine terms are zero. (b) The second term in the series is $-4 \cos x$.
- (c) Coefficient of all the cosine terms are zero. (d) The first term in the series is $\pi^2/3$.

37. The state of a harmonic oscillator is given as $\Psi = \frac{1}{\sqrt{3}}\psi_0 - \frac{1}{\sqrt{6}}\psi_1 + \frac{1}{\sqrt{2}}\psi_2$, where ψ_0 , ψ_1 and ψ_2 are the normalized wave functions of ground, first excited, and second excited state, respectively. Which of the following statement(s) is/are TRUE?



- (a) Expectation value of the energy of the system $\langle E \rangle = \frac{5}{3} \hbar \omega$.
- (b) A measurement of the energy of the system yields $E = \frac{1}{2} \hbar \omega$ with non-zero probability.
- (c) A measurement of the energy of the system yields $E = \frac{5}{3} \hbar \omega$ with non-zero probability.
- (d) Expectation value of the energy of the system $\langle E \rangle = \frac{7}{6} \hbar \omega$.

38. A rod of mass M , length L and non-uniform mass per unit length $\lambda(x) = \frac{3Mx^2}{L^3}$, is held horizontally by a pivot, as shown in the figure, and is free to move in the plane of the figure. For this rod, which of the following statements are true ?

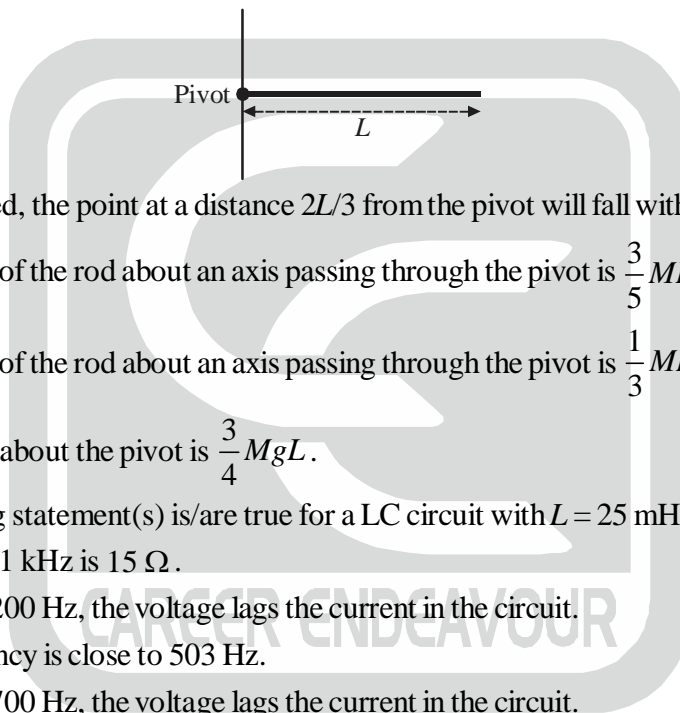

- (a) If the rod is released, the point at a distance $2L/3$ from the pivot will fall with acceleration g .
- (b) Moment of inertia of the rod about an axis passing through the pivot is $\frac{3}{5} ML^2$.
- (c) Moment of inertia of the rod about an axis passing through the pivot is $\frac{1}{3} ML^2$.
- (d) Torque on the rod about the pivot is $\frac{3}{4} MgL$.
39. Which of the following statement(s) is/are true for a LC circuit with $L = 25$ mH and $C = 4$ μ F ?
- (a) The impedance at 1 kHz is 15Ω .
- (b) At a frequency of 200 Hz, the voltage lags the current in the circuit.
- (c) Resonance frequency is close to 503 Hz.
- (d) At a frequency of 700 Hz, the voltage lags the current in the circuit.
40. The spectral energy density $u_T(\lambda)$ vs wavelength (λ) curve of a black body shows a peak at $\lambda = \lambda_{\max}$. If the temperature of the black body is doubled, then
- (a) the area under the curve becomes 16 times the original area.
- (b) the maximum of $u_T(\lambda)$ shifts to $2\lambda_{\max}$.
- (c) the area under the curve becomes 8 times the original area.
- (d) the maximum of $u_T(\lambda)$ shifts to $\lambda_{\max}/2$.

PART-C : NUMERICAL ANSWER TYPE QUESTIONS (NAT)

Q.41 To Q.50 : Each carry ONE mark

41. Two silicon diodes are connected to a battery and two resistors as shown in the figure. The current through the battery is _____ A. [Rounded off to two decimal places]

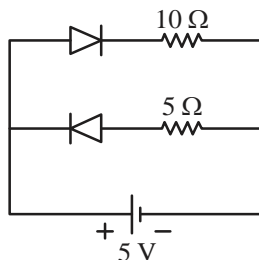

Given: The forward voltage drop across each diode = 0.7 V.

42. The sum of the x -components of unit vectors \hat{r} and $\hat{\theta}$ for a particle moving with angular speed 2 rad s^{-1} at angle $\theta = 215^\circ$ is _____. [Rounded off to two decimal places]
43. A spacecraft has speed $v_s = fc$ with respect to the earth, where c is the speed of light in vacuum. An observer in the spacecraft measures the time of one complete rotation of the earth to be 48 hours. The value of f is _____. [Rounded off to two decimal places]
44. An α particle with energy of 3 MeV is moving towards a nucleus of ^{50}Sn . Its minimum distance of approach to the nucleus is $f \times 10^{-14} \text{ m}$. The value of f is _____. [Rounded off to one decimal place]
45. Consider a spring mass system with mass 0.5 kg and spring constant $k = 2 \text{ Nm}^{-1}$ in a viscous medium with drag coefficient $b = 3 \text{ kg s}^{-1}$. The additional mass required so that the motion becomes critically damped is _____ kg. [Rounded off to three decimal places]
46. A single pendulum hanging vertically in an elevator has a time period T_0 when the elevator is stationary. If the elevator moves upward with an acceleration of $a = 0.2g$. The time period of oscillations is T_1 . Here g is the acceleration due to gravity. The ratio T_0/T_1 is _____. [Rounded off to two decimal places]
47. A rectangular pulse of width 0.5 cm is travelling to the right on a taut string (shown by full line in the figure) that has mass per unit length μ_1 . The string is attached to another taut string (shown by dashed line) of mass per unit length μ_2 . If the tension in both the strings is the same, and the transmitted pulse has width 0.7 cm, the ratio μ_1/μ_2 is _____. [Rounded off to two decimal places]

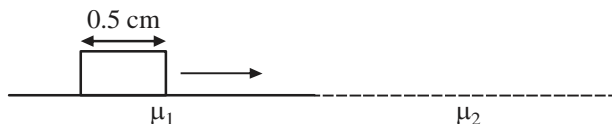

48. The lattice constant (in \AA) of copper, which has FCC structure, is _____. [Rounded off to two decimal places]
Given: Density of copper is 8.91 g cm^{-3} and its atomic mass is 63.55 g mol^{-1} .
Avogadro's number = $6.023 \times 10^{23} \text{ mol}^{-1}$.
49. The absolute error in the value of $\sin \theta$ is approximated up to two terms in the Taylor's series for $\theta = 60^\circ$ is _____. [Rounded off to three decimal places]

50. Unit vector normal to the equipotential surface of $V(x, y, z) = 4x^2 + y^2 + z$ at $(1, 2, 1)$ is given by $(a\hat{i} + b\hat{j} + c\hat{k})$. The value of $|b|$ is _____. [Rounded off to two decimal places]

Q.51 To Q.60 : Each carry TWO marks

51. A fission device explodes into two pieces of rest masses m and $0.5m$ with no loss of energy into any other form. These masses move apart respectively with speeds $\frac{c}{\sqrt{13}}$ and $\frac{c}{2}$, with respect to the stationary frame. If the rest mass of the device is fm , then f is _____. [Rounded off to two decimal places]
52. A point source emitting photons of 2 eV energy and 1 W of power is kept at a distance of 1 m from a small piece of a photoelectric material of area 10^{-4} m^2 . If the efficiency of generation of photoelectrons is 10 %, then the number of photoelectrons generated are $f \times 10^{12}$ per second. The value of f is _____. [Rounded off to two decimal places]
Given: $1 \text{ eV} = 1.6 \times 10^{-19} \text{ J}$

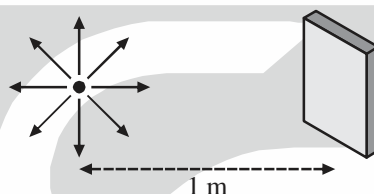

53. Consider the α -decay ${}^{90}\text{Th}^{232} \rightarrow {}^{88}\text{Ra}^{228}$. In an experiment with one gram of ${}^{90}\text{Th}^{232}$. The average count rate (integrated over the entire volume) measured by the α -detector is $3000 \text{ counts s}^{-1}$. If the half life of ${}^{90}\text{Th}^{232}$ is given as $4.4 \times 10^{17} \text{ s}$, then the efficiency of the α -detector is _____. [Rounded off to two decimal places] [Given: Avogadro's number = $6.023 \times 10^{23} \text{ mol}^{-1}$]
54. The sum of the eigenvalues λ_1 and λ_2 of matrix $B = I + A + A^2$, where $A = \begin{bmatrix} 2 & 1 \\ -0.5 & 0.5 \end{bmatrix}$ is _____. [Rounded off to two decimal places]
55. Three frames F_0, F_1 and F_2 are in relative motion. The frame F_0 is at rest, F_1 is moving with velocity $v_1 \hat{i}$ with respect to F_0 and F_2 is moving with velocity $v_2 \hat{i}$ with respect to F_1 . A particle is moving with velocity $v_3 \hat{i}$ with respect to F_2 . If $v_1 = v_2 = v_3 = (c/2)$, where c is the speed of light, the speed of the particle with respect to F_0 is fc . The value of f is _____. [Rounded off to two decimal places]
56. A container of volume V has helium gas in it with N number of He atoms. The mean free path of these atoms is λ_{He} . Another container has Argon gas with the same number of Ar atoms in volume $2V$ with their mean free path being λ_{Ar} . Taking the radius of Ar atoms to be 1.5 times the radius of He atoms, the ratio $\lambda_{\text{Ar}}/\lambda_{\text{He}}$ is _____. [Rounded off to two decimal places]
57. In a X-ray tube operating at 20 kV, the ratio of the de-Broglie wavelength of the incident electrons to the shortest wavelength of the generated X-rays is _____. [Rounded off to two decimal places]
[Given: e/m ratio for an electron = $1.76 \times 10^{11} \text{ Ckg}^{-1}$ and the speed of light in vacuum is $3 \times 10^8 \text{ ms}^{-1}$]

58. A metallic sphere of radius R is held at electrostatic potential V . It is enclosed in a concentric thin metallic shell of radius $2R$ at potential $2V$. If the potential at the distance $\frac{3}{2}R$ from the centre of the sphere is fV , then the value of f is _____. [Rounded off to two decimal places]
59. In the Thomson model of hydrogen atom, the nuclear charge is distributed uniformly over a sphere of radius R . The average potential energy of an electron confined within this atom can be taken as $V = -\frac{e^2}{4\pi\epsilon_0 R}$. Taking the uncertainty in position to be the radius of the atom, the minimum value of R for which an electron will be confined within the atom is estimated to be $f \times 10^{-11}$ m. The value of f is _____.
[Rounded off to one decimal place]
[Given: The uncertainty product of momentum and position is $\hbar = 1 \times 10^{-34}$ Js⁻¹, $e = 1.6 \times 10^{-19}$ C, and $\frac{1}{4\pi\epsilon_0} = 9 \times 10^9$ Nm²C⁻²]
60. A conducting wire AB of length 1 m has resistance of 1.6Ω . It is connected to a voltage source of 0.5 V with negligible resistance as shown in the figure. The corresponding electric and magnetic fields give Poynting vectors $\vec{S}(\vec{r})$ all around the wire. Surface integral $\int \vec{S} \cdot d\vec{a}$ is calculated over a virtual sphere of diameter 0.2 m with its centre on the wire, as shown. The value of the integral is _____ W.
[Rounded off to three decimal places]

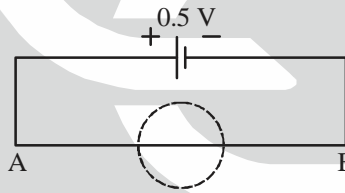

***** End of the Question Paper *****



ANSWER KEY

[PART-A : MULTIPLE CHOICE QUESTIONS (MCQ)]

1. (b)	2. (a)	3. (b)	4. (d)	5. (c)
6. (b)	7. (d)	8. (a)	9. (a)	10. (d)
11. (a)	12. (c)	13. (b)	14. (d)	15. (d)
16. (d)	17. (c)	18. (a)	19. (d)	20. (b)
21. (a)	22. (c)	23. (c)	24. (b)	25. (c)
26. (d)	27. (d)	28. (9.5*)	29. (b)	30. (d)

[PART-B : MULTIPLE SELECTIVE QUESTIONS (MSQ)]

31. (b), (c), (d)	32. (a), (b), (d)	33. (b), (c)	34. (a), (c), (d)	35. (a, b, c)
36. (a), (b), (d)	37. (a), (b)	38. (b), (d)	39. (b), (c)	40. (a), (d)

[PART-C : NUMERICAL ANSWER TYPE QUESTIONS (NAT)]

41. (0.43)	42. (2.79)	43. (0.87)	44. (4.8)	45. (0.625)
46. (1.09)	47. (1.96)	48. (3.62)	49. (0.010)	50. (0.44)
51. (1.62)	52. (2.49)	53. (0.73)	54. (7.75)	55. (0.93)
56. (0.89)	57. (0.14)	58. (1.67)	59. (2.4)	60. (0.031)

